

Student ID: _____

CS 151 Midterm

Name : _____ , _____
(Last Name) (First Name)

Student ID : _____

Signature : _____

Instructions:

1. Please verify that your paper contains **11 pages** including this cover.
2. Write down your Student-Id on the top of each page of this quiz.
3. This exam is **closed book**. No notes or other materials are permitted.
4. Total credits of this midterm are **50 points**.
5. To receive credit you must show your work clearly.
6. **No re-grades will be entertained if you use a pencil.**
7. Calculators are **NOT** allowed.

Student ID: _____

Q1: Memory hierarchy **[10 points]**

Design a 64K*32-bit RAM using 16K*16-bit RAM modules shown below.

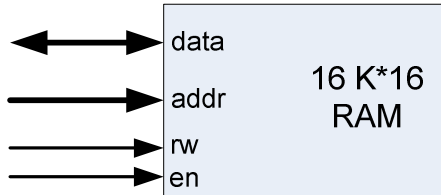

16K*16-bit RAM Module

Use a minimum number of the following logic components in your design (*no other components may be used for this design*):

- 1) Priority Encoder
- 2) Decoder
- 3) Multiplexer

Student ID: _____

<This page is intentionally left blank>

Student ID: _____

Q2: Design of a Traffic Light Controller **[40 points]**

Consider the intersection of Campus and California shown below and consider only the two Traffic Lights (TL) on Campus and California as shown below. Furthermore, assume that traffic on Campus and California are one-way.

Design a digital system that controls the two traffic lights at this intersection with the goal of minimizing congestion by balancing the traffic load. The basic idea is to give more time for cars passing through the road with a higher traffic load.

To determine the traffic load, assume that a sensor on each road registers a pulse when it senses a car passing through that intersection. Assume further that cars pass the intersection ONLY when the traffic light is green, and we count the number of the cars that pass through the intersection.

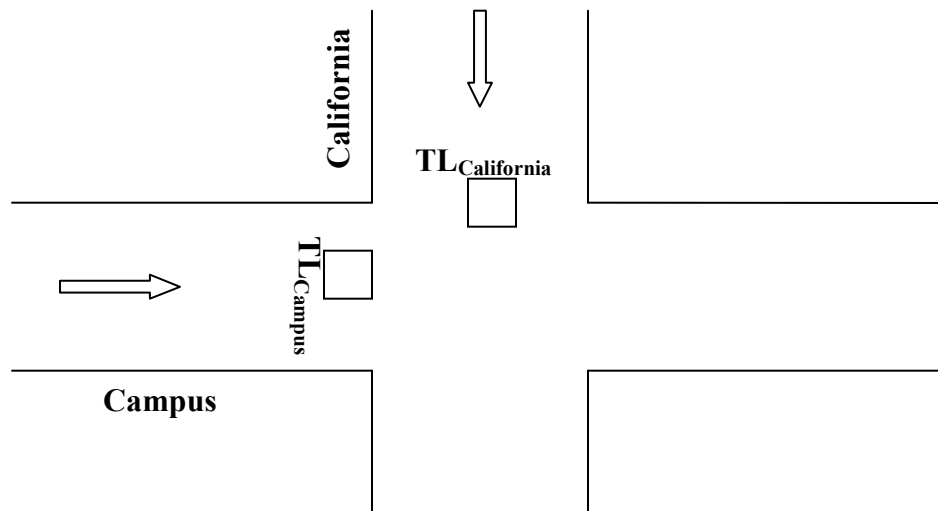

Campus-California Intersection

We estimate the traffic load on each road using the rate at which cars pass through intersection. That is, **Rate(TL) = The number of cars passing through the intersection (while the traffic light is green) divided by number of cycles for that period.**

Based on the comparative traffic loads, the TLs are in one of the following modes:

a) Campus High Mode, where $\text{Rate}(\text{TL}_{\text{Campus}}) \geq 2 * \text{Rate}(\text{TL}_{\text{California}})$:

$\text{TL}_{\text{Campus}}$ is Green for 64 cycles, followed by Yellow for 8 cycles and Red for 40 cycles; concurrently, $\text{TL}_{\text{California}}$ is Red for 72 cycles, Yellow for 8 cycles and Green for 32 cycles.

b) California High Mode, where $\text{Rate}(\text{TL}_{\text{California}}) \geq 2 * \text{Rate}(\text{TL}_{\text{Campus}})$:

$\text{TL}_{\text{California}}$ is Green for 64 cycles, followed by Yellow for 8 cycles and Red for 40 cycles; concurrently, $\text{TL}_{\text{Campus}}$ is Red for 72 cycles, Yellow for 8 cycles and Green for 32 cycles.

c) Comparable Load Mode, where we assume that the rates are comparable:

$\text{TL}_{\text{California}}$ and $\text{TL}_{\text{Campus}}$ are Green for 32 cycles, Yellow for 8 cycles and Red for 40 cycles. (Obviously when $\text{TL}_{\text{Campus}}$ is green or yellow, $\text{TL}_{\text{California}}$ is red and vice versa.)

Student ID: _____

NOTE: To prevent traffic on any road from being stuck at Red indefinitely, make the following assumption: **the traffic mode of the intersection is determined after each intersection has had a Green light once.** For instance, if we start with $TL_{\text{Campus}} = \text{Green}$ we will check for the traffic mode of the intersection only after TL_{Campus} cycles through Yellow and Red, and $TL_{\text{California}}$ cycles through Green, Yellow, Red. After both streets have allowed cars to pass through, we will check for the traffic load to determine the next Load Mode for the intersection.

Assume the initial condition:

$TL_{\text{Campus}} = \text{Green}$, $TL_{\text{California}} = \text{Red}$ and $\text{Rate}(TL_{\text{California}}) = \text{Rate}(TL_{\text{Campus}})$. (We are in **Comparable Load Mode**)

i. Draw a template of the FSM and datapath. (5 points)

(Hint: You just need to show the external inputs and outputs of the system to the controller and datapath shown below. You will design the interface between the datapath and the controller later in this question)

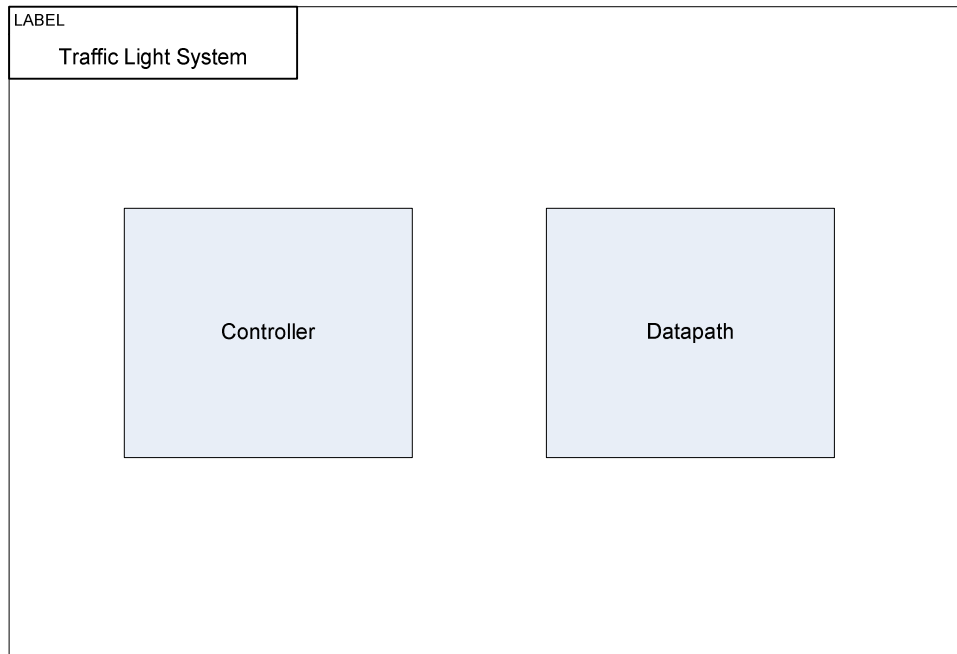

Student ID: _____

- ii. Design the High-Level State Machine for this traffic light system. (10 points)**
(Hint: In your state machine you have 3 different modes and each state in each mode in your state machine shows the status of your traffic lights)
(If necessary, clearly state any *reasonable assumptions* you might make for this part.)

Student ID: _____

- iii. Draw the state action table for this controller. (5 points)**
(A table indicating in each state what actions should be taken.)

Student ID: _____

iv. Design the datapath using components. (10 points)

Use the following block to get the rate on each road. This block gives **Rate(TL) = number of cars passed/number of clock cycles** while Enable=1.

(Hint: You should first store Rate(TL) and then use it.)

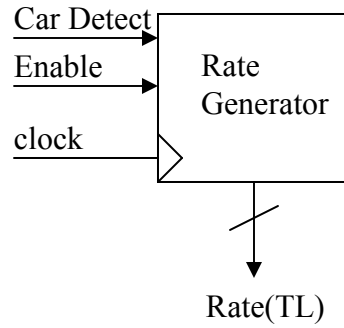

Student ID: _____

<This page is intentionally left blank>

Student ID: _____

- v. **Controller interface: draw the signals between Controller and the Datapath. (5 points)**

Student ID: _____

- vi. Annotate the state diagram with control signals for each state. (5 points)**
(You need not design the FSM controller using Flip Flops and Logic; simply indicate which control signals should be activated in each state for correct operation of the design.)

Student ID: _____