

Student ID: _____

CS 151 Midterm

Name : _____ , _____
(Last Name) (First Name)

Student ID : _____

Signature : _____

Instructions:

1. Please verify that your paper contains **11 pages** including this cover.
2. Write down your Student-Id on the top of each page of this quiz.
3. This exam is **closed book**. No notes or other materials are permitted.
4. Total credits of this midterm are **70 points**.
5. To receive credit you must show your work clearly.
6. **For possible re-grade request make sure that your write clearly.**
7. Calculators are **NOT** allowed.

Student ID: _____

Q1: [ALU]

[20 points]

We are going to design a 4-bit Arithmetic Unit (AU) with the following functional table:

M1	M0	Function Name	F(A,B)
0	0	A + A multiplied by 8 times B	$A*(8*B)+A$
0	1	If (A>B) subtract B from A; otherwise add A and B	If (A>B) then A-B; else A+B
1	0	Decrement A	A-1
1	1	Add 1 to A+B	A+B+1

A and B are two 4-bit binary numbers $a_3a_2a_1a_0$ and $b_3b_2b_1b_0$.

M1, M0 are the control inputs to this AU.

For doing this, the block labeled “AL-Extender” in the following block diagram should be designed.

In this question you should design the logic inside AL-Extender using JUST Comparators and Multiplexers if needed.

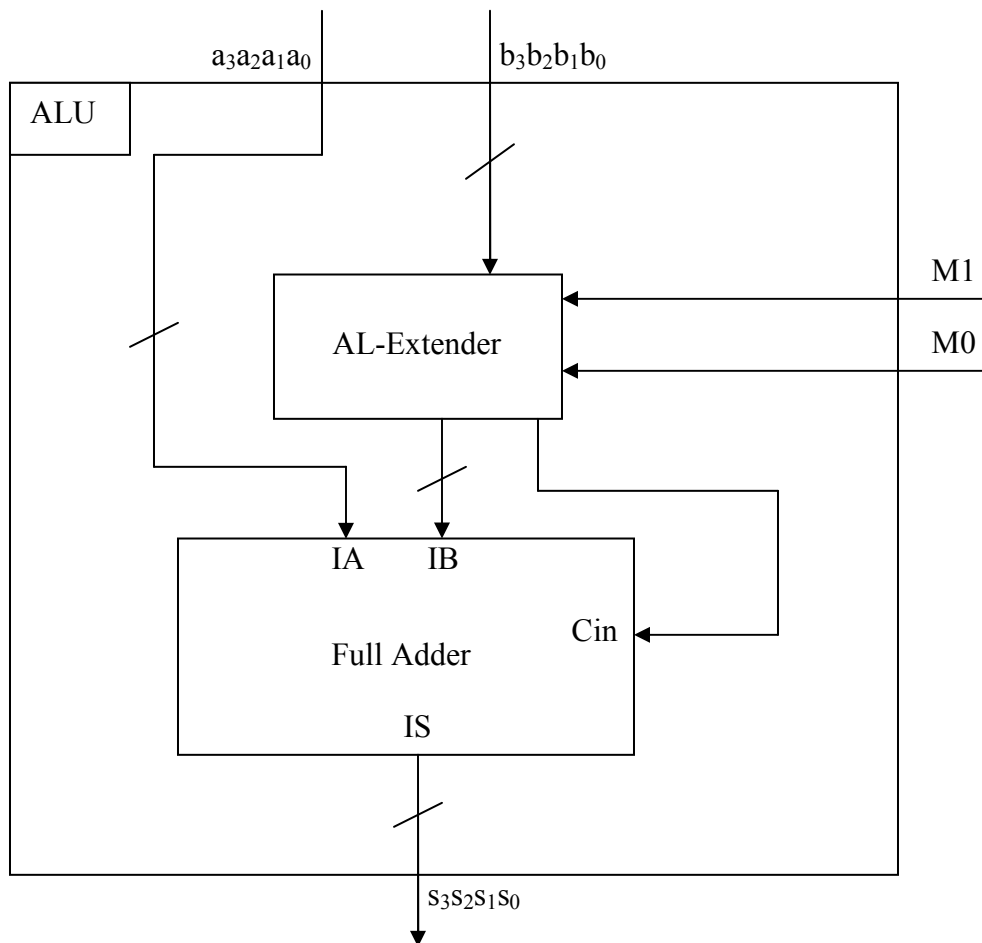

Student ID: _____

<This page is intentionally left blank>

Student ID: _____

<This page is intentionally left blank>

Student ID: _____

Q2: [High-Level State Machine Design] _____ [15 points]

Design the high-level state machine for a DVD player with the following functionality: Initially when we turn on the system it is in **STOP** mode and we can assume that there is a DVD already inserted in. The DVD player has four buttons: **STOP**, **PLAY**, **FF** (Fast Forward) and **FB** (Fast Backward). While in **STOP mode** if we hit **STOP** or **FF** or **FB** button we should stay at the same state. As well whenever we reach the **STOP** mode the value of the timer resets to **ZERO**. Once we hit **PLAY** button, the DVD player starts playing and every cycle the timer of the player is incremented by one unless it reaches the end of the DVD (time 200) when it goes to **STOP** mode automatically. While in play mode if we hit **FF** button and keep it depressed for just one clock cycle the timer is incremented by 50 and then we automatically go back to play mode. If we hit the **FF** button the next clock cycle the DVD player goes to **Fast Forward mode** and the timer is incremented by 5 for each cycle. The DVD player will remain at the same state unless: we hit the **PLAY** button or the **FB** button which takes us to the **PLAY** mode; or the end of the DVD is reached or we hit the **STOP** button which puts the player in **STOP** mode; The same thing happens if we push **FB** button with the difference that the timer is decremented by the same amount of **FF** mode. The player remains at **FB** mode unless: we hit the **PLAY** button or the **FF** button which takes the player to the **PLAY** mode; the beginning of the DVD is reached where the timer is set to **ZERO** and the player goes to the **PLAY** mode automatically; the **STOP** button is hit which puts the player in **STOP** mode;

Student ID: _____

<This page is intentionally left blank>

Student ID: _____

Q3: [RTL design]

[35 points]

Considering the following high-level state machine and assuming that X, Y, START and STOP are one bit control inputs and T is an 8-bit output of the circuit:

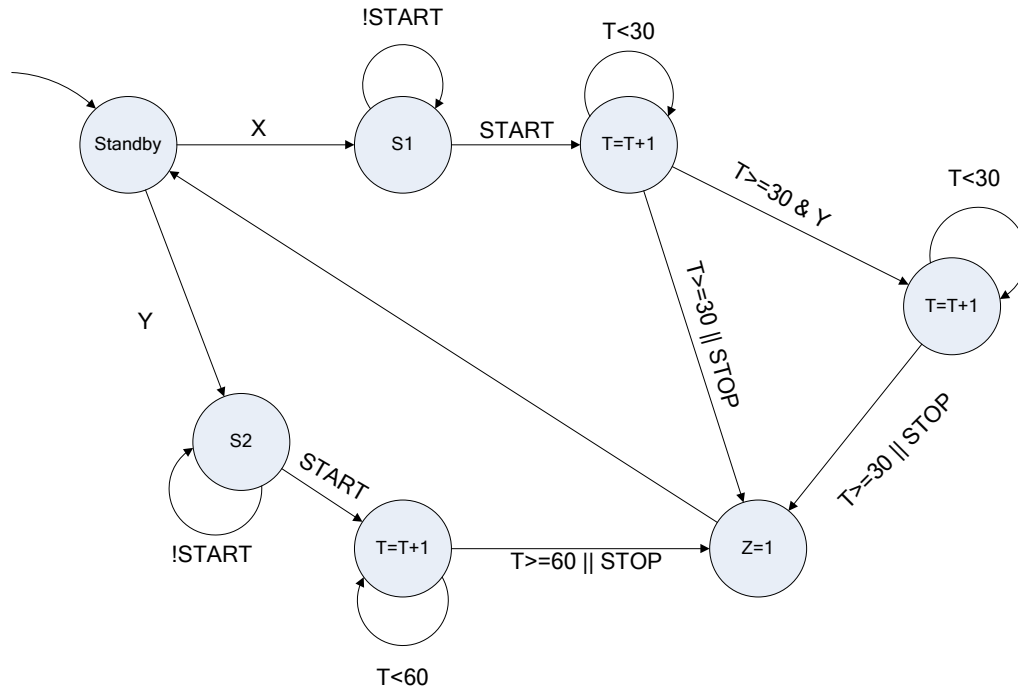

Student ID: _____

3a. Design the data-path for this system. [15 points]

Student ID: _____

3b. Design the interface of the system and the interface between the controller and the datapath. [5 points]

Student ID: _____

3c. Design the FSM of the controller. [15 points]

HINT: There is no timing issue for this system so you do not have to consider timing issues in designing the controller's FSM.

Student ID: _____

<This page is intentionally left blank>