

Student ID: _____

CS 151 Quiz 3

Name : _____ , _____
(Last Name) (First Name)

Student ID : _____

Signature : _____

Instructions:

1. Please verify that your paper contains **8 pages** including this cover.
2. Write down your Student-Id on the top of each page of this quiz.
3. This exam is **closed book**. No notes or other materials are permitted.
4. Total credits of this quiz are **45 points**.
5. To receive credit you must show your work clearly.
6. **No re-grades will be entertained if you use a pencil.**
7. Calculators are **NOT** allowed.

Student ID: _____

Q1: [Controller Design]

[15 points]

Considering the FSM shown below:

X is the input to the FSM and Y is the output associated with each state.

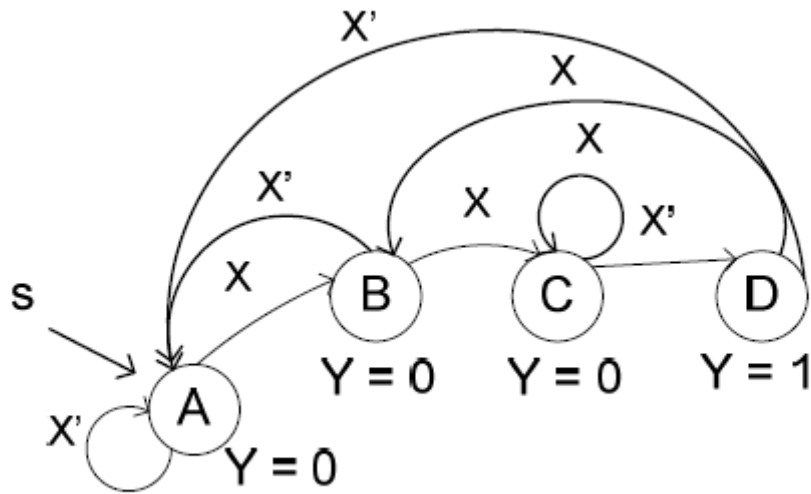

a) Create the architecture for this FSM. [5 points]

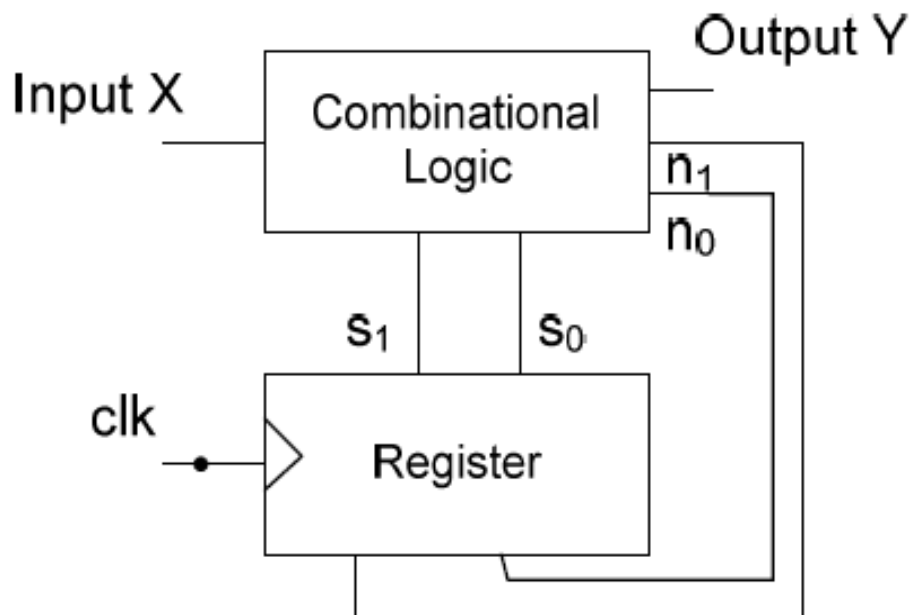

Student ID: _____

b) Considering the state encoding shown below, draw the state table. [10 points]

A = 00, B = 01, C = 10, D = 11

NOTE: Just write the equation for the output Y.

s1	s0	X	n1	n0	Y
0	0	0	0	0	0
0	0	1	0	1	0
0	1	0	0	0	0
0	1	1	1	0	0
1	0	0	1	1	0
1	0	1	1	0	0
1	1	0	0	0	1
1	1	1	0	1	1

$$Y = S1S0$$

Student ID: _____

Q2: [FSM Design]

[10 points]

Design an FSM which detects strings of the form $1(01)^*$ on the stream of input X. On the detection of the string, an output Y should become 1.

$1(01)^*$ are a class of strings that start from 1, followed by any number of 01 (at least 0).

NOTE: 1, 101, 101...01, etc are some samples of a string of form $1(01)^*$.

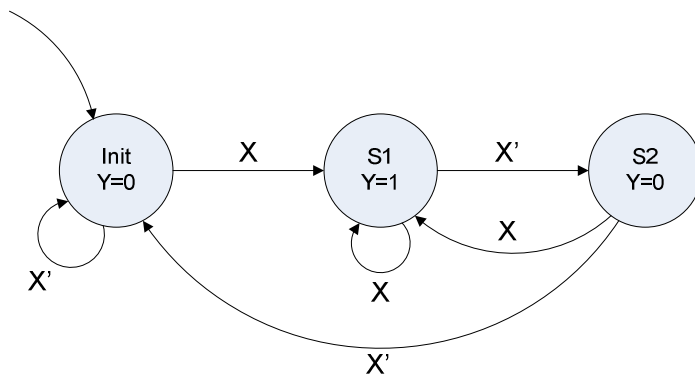

Student ID: _____

<This page is intentionally left blank>

Student ID: _____

Q3: [Registers] [20 points]

Design inside the Black Box below to implement a 4-bit register with the functionality specified in the following table. ($A = a_3a_2a_1a_0$ is the output of the register.)

$B = b_3b_2b_1b_0$ is the input to the register.

NOTE: Specify the select lines of each multiplexer as well as the inputs. You can use the following components if needed.

- Adder
- Comparator
- Logic gates
- Multiplexer

S_1S_0	Action	Output
00	Load	$b_3b_2b_1b_0$
01	Keep current value	A
10	If $(B > A) \rightarrow$ Load B; else Keep current value	If $(B > A) \rightarrow B$; else A;
11	If $(B > 2 * A) \rightarrow$ Load $B/2$; else Load $A/2$	If $(B > 2 * A) \rightarrow B/2$; else $A/2$;

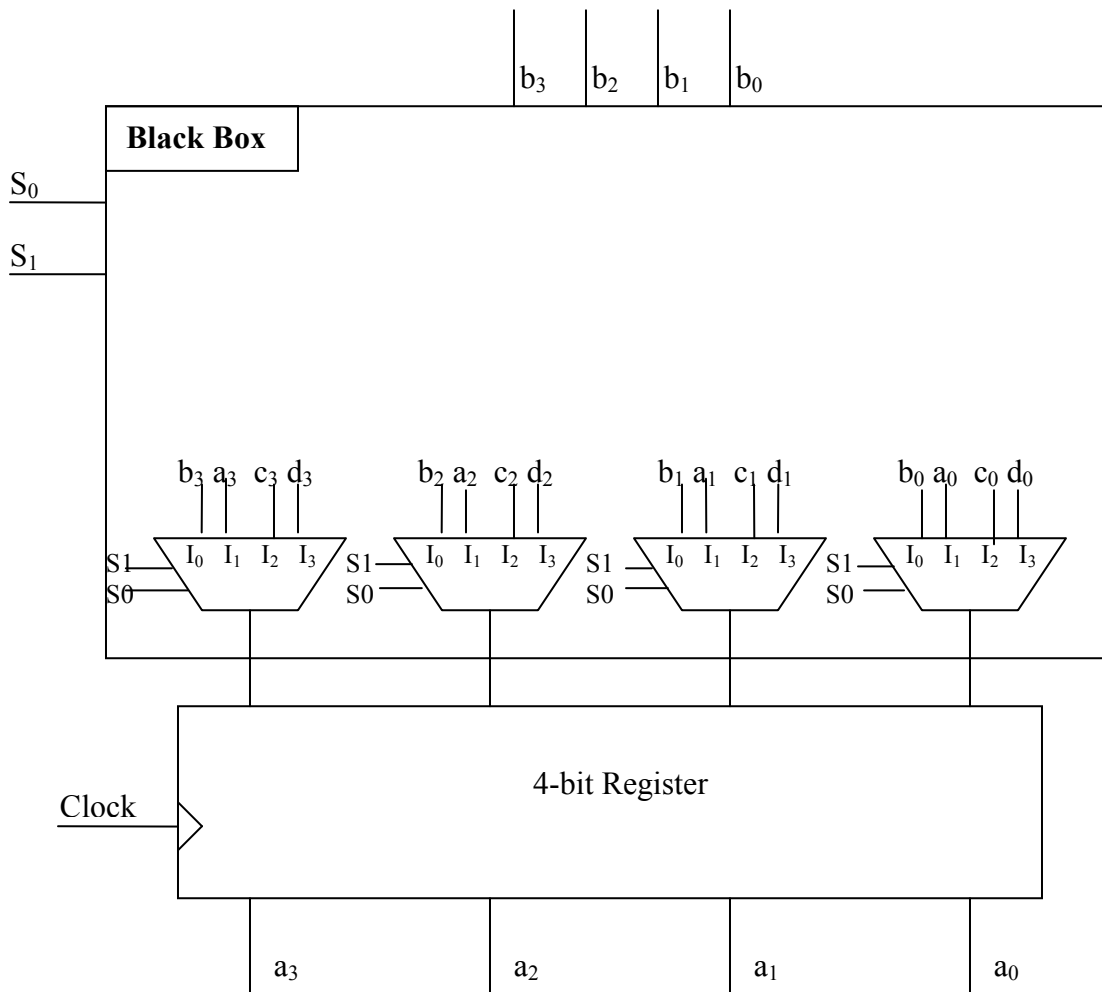

Student ID: _____

<This page is intentionally left blank>

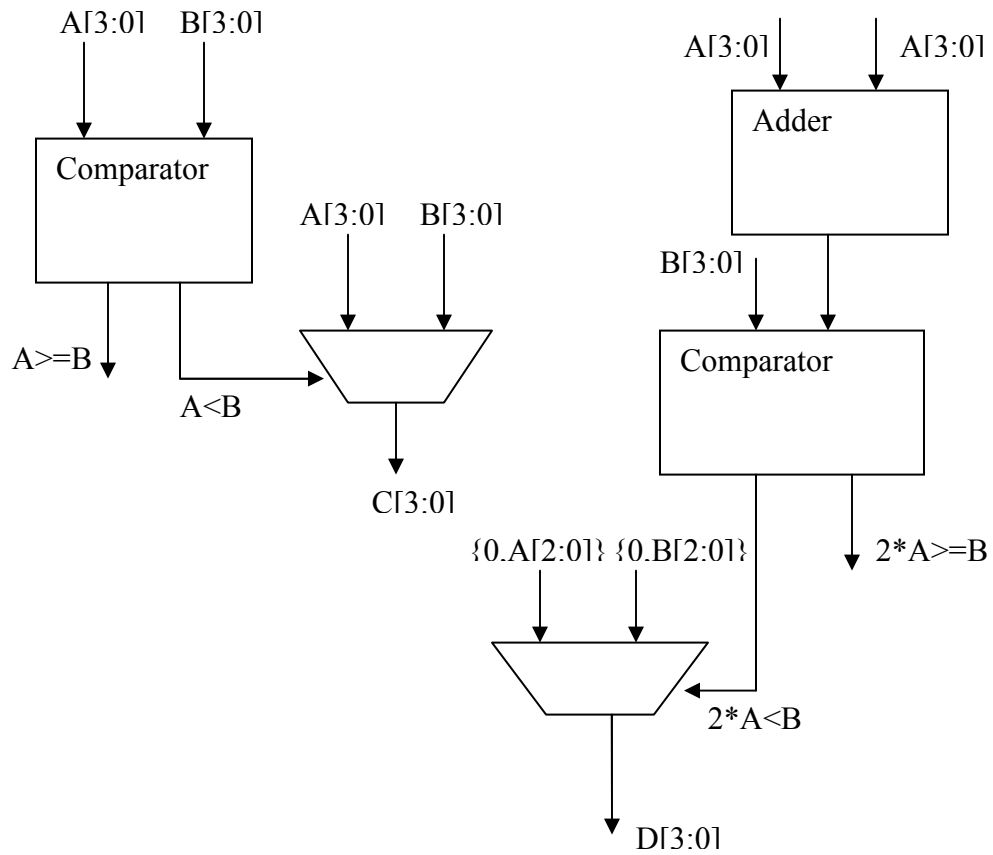

Student ID: _____

<This page is intentionally left blank>