

Student ID: \_\_\_\_\_

# CS 151 Quiz 4

Name : \_\_\_\_\_ , \_\_\_\_\_  
(Last Name) (First Name)

Student ID : \_\_\_\_\_

Signature : \_\_\_\_\_

## **Instructions:**

1. Please verify that your paper contains **7 pages** including this cover.
2. Write down your Student-Id on the top of each page of this quiz.
3. This exam is **closed book**. No notes or other materials are permitted.
4. Total credits of this quiz are **45 points**.
5. To receive credit and for possible re-grade request you must show your work clearly.
6. **For possible re-grade request make sure that your write clearly.**
7. Calculators are **NOT** allowed.

Student ID: \_\_\_\_\_

**Q1: [ALU Design]**

**[10 points]**

We want to design a 4-bit Arithmetic Unit (AU) with the following functional table:

M	Function Name	F(A,B)
0	Add A and 2*B	A+2*B
1	Subtract B from A	A-B

A = a<sub>1</sub>a<sub>0</sub> and B = b<sub>1</sub>b<sub>0</sub> are two 2-bit binary numbers which should be extended to 4-bit numbers a<sub>3</sub>a<sub>2</sub>a<sub>1</sub>a<sub>0</sub> and b<sub>3</sub>b<sub>2</sub>b<sub>1</sub>b<sub>0</sub>.

M is the control input to this AU.

For doing this, the blocks labeled “Black Box” and CE (Carry Extender) in the following block diagram should be designed:

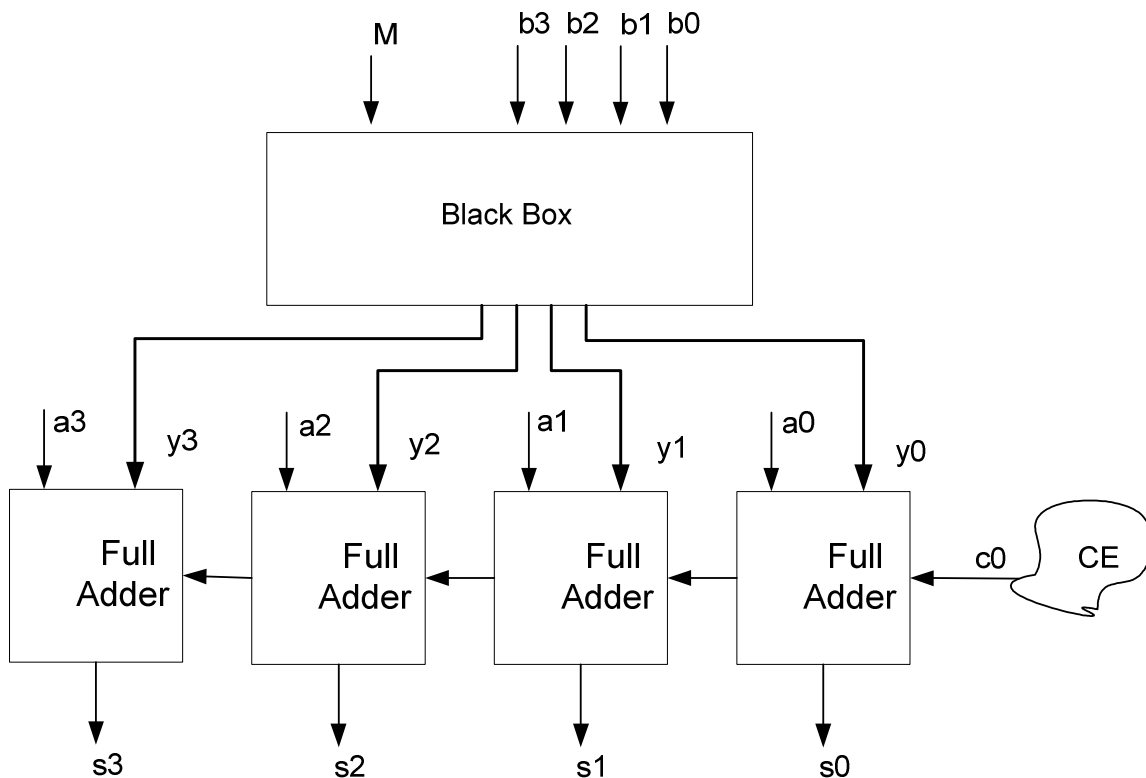

Student ID: \_\_\_\_\_

Fill the following table for  $y_3, y_2, y_1, y_0, a_3, a_2$  and  $c_0$  based on the inputs of the AU which are  $a_1, a_0, b_1, b_0$  and  $M$ . [10 points]

<b>M</b>	<b>y3</b>	<b>y2</b>	<b>y1</b>	<b>y0</b>	<b>a3</b>	<b>a2</b>	<b>c0</b>
<b>0</b>							
<b>1</b>							

Student ID: \_\_\_\_\_

**Q2: [Data Path and Controller Design]**

**[35 points]**

Considering the following high-level state machine and assuming that CLR, LD and UD are one bit control inputs and SUM and I are 8-bit output and input (respectively) of the circuit:

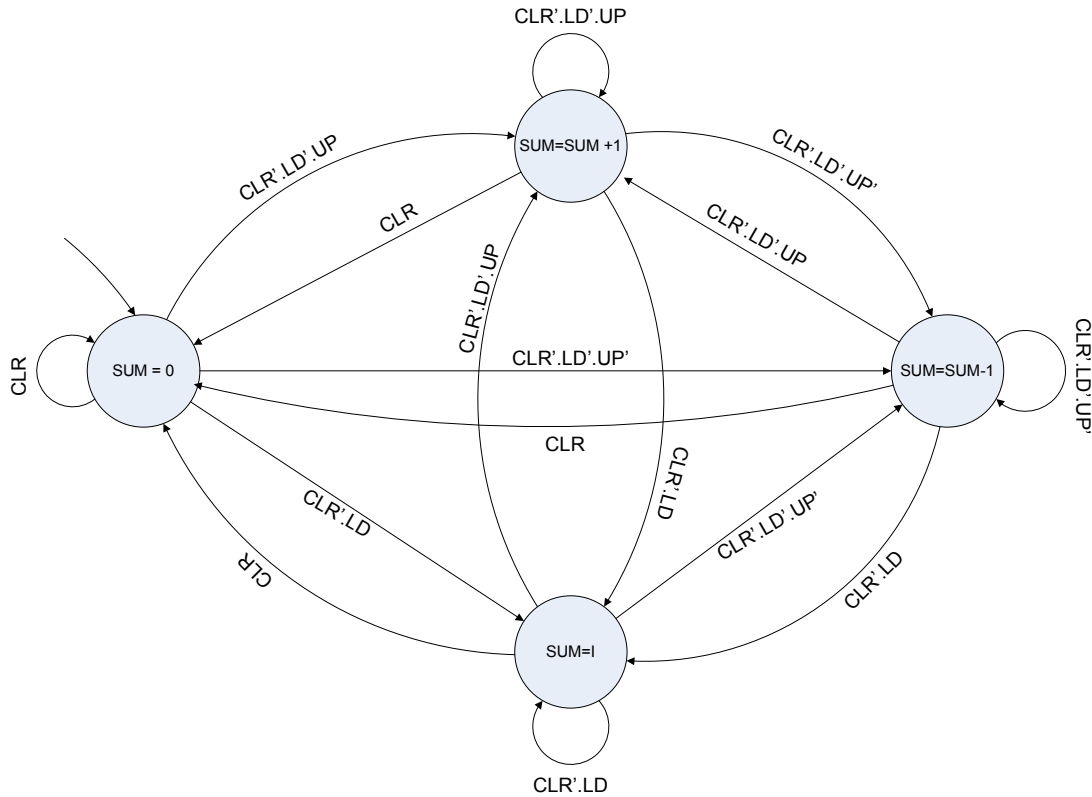

Student ID: \_\_\_\_\_

**1. Design the data-path for this system. [15 points]**

Student ID: \_\_\_\_\_

- 2. Design the interface of the system and the interface between the controller and the datapath. [5 points]**

Student ID: \_\_\_\_\_

**3. Design the FSM of the controller. [15 points]**

HINT: There is no timing issue for this system so you do not have to consider timing issues in designing the controller's FSM.