

Practical Oblivious Storage

Michael T. Goodrich
Dept. of Computer Science
University of California, Irvine
goodrich@ics.uci.edu

Olga Ohrimenko
Dept. of Computer Science
Brown University
olya@cs.brown.edu

Michael Mitzenmacher
Dept. of Computer Science
Harvard University
michaelm@eecs.harvard.edu

Roberto Tamassia
Dept. of Computer Science
Brown University
rt@cs.brown.edu

ABSTRACT

We study *oblivious storage* (OS), a natural way to model privacy-preserving data outsourcing where a client, Alice, stores sensitive data at an honest-but-curious server, Bob. We show that Alice can hide both the content of her data and the pattern in which she accesses her data, with high probability, using a method that achieves $O(1)$ amortized rounds of communication between her and Bob for each data access. We assume that Alice and Bob exchange small messages, of size $O(N^{1/c})$, for some constant $c \geq 2$, in a single round, where N is the size of the data set that Alice is storing with Bob. We also assume that Alice has a private memory of size $2N^{1/c}$. These assumptions model real-world cloud storage scenarios, where trade-offs occur between latency, bandwidth, and the size of the client's private memory.

Categories and Subject Descriptors

K.6.5 [Management of Computing and Information Systems]: Security and Protection

General Terms

Algorithms, Security

1. INTRODUCTION

Outsourced data management is a large and growing industry. For example, as of July 2011, Amazon S3 [2] reportedly stores more than 400 billion objects, which is four times its size from the year before, and the Windows Azure service [15], which was started in late 2008, is now a multi-billion dollar enterprise.

With the growing impact of online cloud storage technologies, there is a corresponding growing interest in methods for privacy-preserving access to outsourced data. Namely, it is anticipated that many customers of cloud storage services

will desire or require that their data remain private. A necessary component of private data access, of course, is to encrypt the objects being stored. But information can be leaked from the way that data is accessed, even if it is encrypted (see, e.g., [5]). Thus, privacy-preserving data access must involve both encryption and techniques for obfuscating the patterns in which users access data.

1.1 Problem Statement

The classic model for the obfuscation of the access pattern is *oblivious RAM simulation*. We use the related *oblivious storage* model, which has been recently proposed. These models are outlined in the rest of this section.

In the *oblivious random access machine (ORAM)* simulation [8] approach, the client, Alice, is modeled as a CPU with a limited-size cache that accesses a large indexed memory managed by the owner of the data service, Bob. The goal is for Alice to perform an arbitrary RAM computation while completely obscuring from Bob the data items she accesses and the access pattern. Unfortunately, although known ORAM simulations [1, 6, 8, 9, 10, 14, 17, 20, 22] can be adapted to the problem of privacy-preserving access to outsourced data, they do not naturally match the interfaces provided by existing cloud storage services, which are not organized according to the RAM model (e.g., see [4]).

A notable exception to this aspect of previous work on ORAM simulation is a recent paper by Boneh *et al.* [4], who introduce the *oblivious storage (OS)* model. In this model, the storage provided by Bob is viewed more realistically as a collection of key-value pairs and the query and update operations supported by his API are likewise more accurately viewed in terms of operations dealing with key-value pairs, which we also call *items*. An OS solution is *oblivious* in this context if an honest-but-curious polynomial-time adversary is unable to distinguish between the (obfuscated) versions of two possible access sequences of equal length and maximum set size, which are polynomially related, beyond a negligible probability. Although the solution to the OS problem given by Boneh *et al.* is somewhat complicated, it is nevertheless considerably simpler than most of the existing ORAM solution techniques. In particular, it avoids additional details required of ORAM simulations that must deal with the obfuscation of an arbitrary RAM algorithm. Thus, an argument can be made that the OS approach is both more realistic and supports simpler oblivious simulations. The goal of this paper, then, is to explore further simplifications

Permission to make digital or hard copies of all or part of this work for personal or classroom use is granted without fee provided that copies are not made or distributed for profit or commercial advantage and that copies bear this notice and the full citation on the first page. To copy otherwise, to republish, to post on servers or to redistribute to lists, requires prior specific permission and/or a fee.

CODASPY'12, February 7–9, 2012, San Antonio, Texas, USA.
Copyright 2012 ACM 978-1-4503-1091-8/12/02 ...\$10.00.

and improvements to achieve practical solutions to the oblivious storage problem.

1.2 Related Previous Work

Research on oblivious simulation of one computational model by another began with Pippenger and Fischer [18], who show that one can obliviously simulate a computation of a one-tape Turing machine computation of length N with an two-tape Turing machine computation of length $O(N \log N)$. That is, they show how to perform such an oblivious simulation with a computational overhead that is $O(\log N)$.

Goldreich and Ostrovsky [8] show that one can perform an oblivious RAM (ORAM) simulation using an outsourced data server and they prove a lower bound implying that such simulations require an overhead of at least $\Omega(\log N)$, for a RAM memory of size N , under some reasonable assumptions about the nature of such simulations. For the case where Alice has only a constant-size private memory, they show how Alice can easily achieve an overhead of $O(N^{1/2} \log N)$, using a scheme called the “square-root solution,” with $O(N)$ storage at Bob’s server. With a more complicated scheme, they also show how Alice can achieve an overhead of $O(\log^3 N)$ with $O(N \log N)$ storage at Bob’s server, using a scheme called the “hierarchical solution.”

Williams and Sion [22] provide an ORAM simulation for the case when the data owner, Alice, has a private memory of size $O(N^{1/2})$. They achieve an expected amortized time overhead of $O(\log^2 N)$ using $O(N \log N)$ memory at the external data provider, Bob. Additionally, Williams *et al.* [23] claim a result that uses an $O(N^{1/2})$ -sized private memory and achieves $O(\log N \log \log N)$ amortized time overhead with a linear-sized outsourced storage, but some researchers (e.g., see [17]) have raised concerns with the assumptions and analysis of this result. Likewise, Pinkas and Reinman [17] published an ORAM simulation result for the case where Alice maintains a constant-size private memory, claiming that Alice can achieve an expected amortized overhead of $O(\log^2 N)$ while using $O(N)$ storage space, but Kushilevitz *et al.* [14] have raised correctness issues with this result as well [14]. Goodrich and Mitzenmacher [9] show that one can achieve an overhead of $O(\log^2 N)$ in an ORAM simulation, with high probability, for a client with constant-sized local memory, and $O(\log N)$, for a client with $O(N^\epsilon)$ memory, for a constant $\epsilon > 0$. Kushilevitz *et al.* [14] also show that one can achieve an overhead of $O(\log^2 N / \log \log N)$ in an ORAM simulation, with high probability, for a client with constant-sized local memory. Ajtai [1] proves that ORAM simulation can be done with polylogarithmic overhead without cryptographic assumptions about the existence of random hash functions, as is done in the papers mentioned above (and this paper), and a similar result is given by Damgård *et al.* [6].

The importance of privacy protection in outsourced data management naturally raises the question of the practicality of the previous ORAM solutions. Unfortunately, the above-mentioned theoretical results contain several complications and hidden constant factors that make these solutions less than ideal for real-world use. Stefanov *et al.* [20] study the ORAM simulation problem from a practical point of view, with the goal of reducing the worst-case bounds for data accesses. They show that one can achieve an amortized overhead of $O(\log N)$ and worst-case performance $O(N^{1/2})$, with $O(\epsilon N)$ storage on the client, for a constant $0 < \epsilon < 1$, and

an amortized overhead of $O(\log^2 N)$ and similar worst-case performance, with a client-side storage of $O(N^{1/2})$, both of which have been hidden constant factors than previous ORAM solutions. Goodrich *et al.* [10] similarly study methods for improving the worst-case performance of ORAM simulation, showing that one can achieve a worst-case overhead of $O(\log N)$ with a client-side memory of size $O(N^\epsilon)$, for any constant $\epsilon > 0$.

As mentioned above, Boneh *et al.* [4] introduce the *oblivious storage* (OS) problem and argue how it is more realistic and natural than the ORAM simulation problem. They study methods that separate access overheads and the overheads needed for rebuilding the data structures on the server, providing, for example, $O(1)$ amortized overhead for accesses with $O((N \log N)^{1/2})$ overhead for rebuilding operations, assuming a similar bound for the size of the private memory on the client.

1.3 Our Results

In this paper, we study the oblivious storage (OS) problem, providing solutions that are parameterized by the two critical components of an outsourced storage system:

- N : the number of items that are stored at the server
- M : the maximum number of items that can be sent or received in a single message, which we refer to as the *message size*.

We assume that the objects being outsourced to Bob’s cloud storage are all of the same size, since this is a requirement to achieve oblivious access. Thus, we can simply refer to the memory and message sizes in terms of the number of items that are stored. This notation is borrowed from the literature on external-memory algorithms (e.g., see [21]), since it closely models the scenario where the memory needed by a computation exceeds its local capacity so that external storage is needed. In keeping with this analogy to external-memory algorithms, we refer to each message that is exchanged between Alice and Bob as an *I/O*, each of which, as noted above, is of size at most M . We additionally assume that Alice’s memory is of size at least $2M$, so that she can hold two messages in her local memory. In our case, however, we additionally assume that $M \geq N^{1/c}$, for some constant $c \geq 2$. This assumption is made for the sake of realism, since even with $c = 3$, we can model Bob storing exabytes for Alice, while she and he exchange individual messages measured in megabytes. Thus, we analyze our solutions in terms of the constant

$$c = \log_M N.$$

We give practical solutions to the oblivious storage problem that achieve an efficient amortized number of I/Os exchanged between Alice and Bob in order to perform put and get operations.

We first present a simple “square-root” solution, which assumes that M is $N^{1/2}$, so $c = 2$. This solution is not oblivious, however, if the client requests items that are not in the set. So we show how to convert any oblivious storage solution that cannot tolerate requests for missing items to a solution that can support obliviously also such requests. With these tools in hand, we then show how to define an inductive solution to the oblivious storage problem that achieves a

Method	I/Os (Number of messages)		Message Size (M)	Client Memory	Server Storage
	Online	Amortized			
Williams <i>et al.</i> [23]	$O(\log N \log \log N)$	$O(\log N \log \log N)$	$O(N^{1/2})$	$O(N^{1/2})$	$O(N)$
Shi <i>et al.</i> [19]	$O(\log N)$	$O(\log N)$	$O(\log^2 N)$	$O(\log^2 N)$	$O(N \log N)$
Goodrich <i>et al.</i> [10]	$O(\log N)$	$O(\log N)$	$O(1)$	N^ν	$O(N)$
Boneh <i>et al.</i> [4]	$O(1)$	$O(\log N)$	$N^{1/2}$	$O(N^{1/2})$	$N + 2N^{1/2}$
Our Method $N^{1/2}$	$O(1)$	$O(1)$	$N^{1/2}$	$2N^{1/2}$	$N + N^{1/2}$
Our Method $N^{1/c}$	$O(1)$	$O(1)$	$N^{1/c}$	$cN^{1/c}$	$N + 2 \sum_{i=1}^{c-2} N^{(c-i)/c}$

Table 1: Comparison between selected oblivious storage approaches. Online I/Os refers to the number of accesses performed to retrieve the requested item. Note that additional I/Os may be required before the next request can be processed. Thus, we also give the amortized number of I/Os per request. Message size (M) refers to the number of items that can be transferred in a single I/O. We denote with N the number of items outsourced to the server and with c and ν arbitrary constants such that $c \geq 2$ and $0 < \nu < 1$. The message size, client memory, and server storage are measured in terms of the number of items. Also, we note that the constant factor in the $O(1)$ access overhead for our $N^{1/c}$ method depends on constant c .

constant amortized number of I/Os for each access, assuming $M = N^{1/c}$. We believe that $c = 2$, $c = 3$, and $c = 4$ are reasonable choices in practice, depending on the relative sizes of M and N .

The operations in these solutions are factored into *access operations* and *rebuild operations*, as in the approach advocated by Boneh *et al.* [4]. Access operations simply read or write individual items to/from Bob’s storage and are needed to retrieve the requested item, whereas rebuild operations may additionally restructure the contents of Bob’s storage so as to mask Alice’s access patterns. In our solutions, access operations use messages of size $O(1)$ while messages of size M are used only for rebuild operations.

An important ingredient in all oblivious storage and oblivious RAM solutions is a method to obliviously “shuffle” a set of elements so that Bob cannot correlate the location of an element before the shuffle with that after the shuffle. This is usually done by using an oblivious sorting algorithm, and our methods can utilize such an approach, such as the external-memory oblivious sorting algorithm of Goodrich and Mitzenmacher [9].

In this paper, we also introduce a new simple shuffling method, which we call the *buffer shuffle*. We show that this method can shuffle with high probability with very little information leakage, which is likely to be sufficient in practice in most real-world oblivious storage scenarios. Of course, if perfectly oblivious shuffling is desired, then this shuffle method can be replaced by external-memory sorting, which increases the I/O complexity of our results by at most a constant factor (which depends on c).

In Table 1, we summarize our results and compare the main performance measures of our solutions with those of selected previous methods that claim to be practical.

1.4 Organization of the Paper

The rest of this paper is organized as follows. In Section 2, we overview the oblivious storage model and its security properties and describe some basic techniques used in previous work. Our buffer shuffle method is presented and analyzed in Section 3. We give a preliminary miss-intolerant square-root solution in Section 4. Section 5 derives a miss-tolerant solution from our square-root solution using a cuckoo hashing scheme. In Section 6, we show how

to reduce the storage requirement at the client. Finally, in Section 7, we describe our experimental results and provide estimates of the actual time overhead and monetary cost of our method, obtained by a prototype implementation and simulation of the use of our solution on the Amazon S3 storage service.

2. THE OBLIVIOUS STORAGE MODEL

In this section, we discuss the OS model using the formalism of Boneh *et al.* [4], albeit with some minor modifications. As mentioned above, one of the main differences between the OS model and the classic ORAM model is that the storage unit in the OS model is an *item* consisting of a key-value pair. Thus, we measure the size of messages and of the storage space at the client and server in terms of the number of items.

2.1 Operations and Messages

Let S be the set of data items. The server supports the following operations on S .

- **get(k)**: if S contains an item, (k, v) , with key k , then return the value, v , of this item, else return null.
- **put(k, v)**: if S contains an item, (k, w) , with key k , then replace the value of this item with v , else add to S a new item (k, v) .
- **remove(k)**: if S contains an item, (k, v) , with key k , then delete from S this item and return its value v , else return null.
- **getRange(k_1, k_2, m)**: return the first m items (by key order) in S with keys in the range $[k_1, k_2]$. Parameter m is a cut-off to avoid data overload at the client because of an error. If there are fewer than m such items, then all the items with keys in the range $[k_1, k_2]$ are returned.
- **removeRange(k_1, k_2)**: remove from S all items with keys in the range $[k_1, k_2]$.

The interactions between the client, Alice, and the server, Bob, are implemented with messages, each of which is of size at most M , i.e., it contains at most M items. Thus,

Alice can send Bob a single message consisting of M put operations, each of which adds a single item. Such a message would count as a single I/O. Likewise, the response to a `getRange(k_1, k_2, m)` operation requires $O(\lceil m/M \rceil)$ I/Os; hence, Alice may wish to limit m to be $O(M)$. Certainly, Alice would want to limit m to be $O(M)$ in most cases, since she would otherwise be unable to locally store the entire result of such a query if it reaches its cut-off size.

As mentioned above, our use of parameter M is done for the sake of practicality, since it is unreasonable to assume that Alice and Bob can only communicate via constant-sized messages. Indeed, with network connections measured in gigabits per second but with latencies measured in milliseconds, the number of rounds of communication is likely to be the bottleneck, not bandwidth. Thus, because of this orders-of-magnitude difference between bandwidth and latency, we assume

$$M \geq N^{1/c},$$

for some fixed constant $c \geq 2$, but that Alice’s memory is smaller than N . Equivalently, we assume that $c = \log_M N$ is a constant. For instance, as highlighted above, if Bob’s memory is measured in exabytes and we take $c = 3$, then we are reasonably assuming that Alice and Bob can exchange messages whose sizes are measured in megabytes. To assume otherwise would be akin to trying to manage a large reservoir with a pipe the size of a drinking straw.

We additionally assume that Alice has a private memory of size bM , in which she can perform computations that are hidden from the server, Bob. To motivate the need for Alice outsourcing her data, while also allowing her to communicate effectively with Bob, we assume that $b \geq 2$ and $2M < N$.

2.2 Basic Techniques

Our solution employs several standard techniques previously introduced in the oblivious RAM and oblivious storage literature. To prevent Bob from learning the original keys and values and to make it hard for Bob to associate subsequent access to the same item, Alice replaces the original key, k , of an item with a new key $k' = h(r||k)$, where h is a cryptographic hash function (i.e., one-way and collision-resistant) and r is a secret randomly-generated nonce that is periodically changed by Alice so that a subsequent access to the same item uses a different key. Note that Bob learns the modified keys of the items. However, he cannot derive from them the original keys due to the one-way property of the cryptographic hash function used. Also, the uniqueness of the new keys occurs with overwhelming probability due to collision resistance.

Likewise, before storing an item’s value, v , with Bob, Alice encrypts v using a probabilistic encryption scheme. E.g., the ciphertext is computed as $E(r||v)$, where E is a deterministic encryption algorithm and r is a random nonce that gets discarded after decryption. Thus, a different ciphertext for v is generated each time the item is stored with Bob. As a consequence, Bob cannot determine whether v was modified and cannot track an item by its value. The above obfuscation capabilities are intended to make it difficult for Bob to correlate the items stored in his memory at different times and locations, as well as make it difficult for Bob to determine the contents of any value.

We distinguish two types of OS solutions. We say that an oblivious storage solution is *miss-intolerant* if it does

not allow for `get` requests that return `null`. Thus, Alice must know in advance that Bob holds an item with the given key. In applications that by design avoid requests for missing items, this restriction allows us to design an efficient oblivious-storage solution, since we don’t have to worry about any information leakage that comes from queries for missing keys. Alternatively, if an oblivious storage solution is oblivious even when accesses can be made to keys that are not in the set, then we say that the solution is *miss-tolerant*.

2.3 Security Properties

Our OS solution is designed to satisfy the following security properties, where the adversary refers to Bob (the server) or a third party that eavesdrops the communication between Alice (the client) and Bob. The adversary is assumed to have polynomially bounded computational power.

Confidentiality. Except with negligible probability, the adversary should be unable to determine the contents (key or value) of any item stored at the server. This property is assured by the techniques described in the previous subsection.

Hardness of Correlation. Except with negligible or very low probability beyond $1/2$, the adversary should be unable to distinguish between any two possible access sequences of equal length and maximum set size. That is, consider two possible access sequences, σ_1 and σ_2 , that consist of L operations, `get`, `put`, and `remove`, that could be made by Alice, on a set of size up to N , where L is polynomial in N . Then an oblivious storage (OS) solution has *correlation hardness* if it applies an obfuscating transformation so that, after seeing the sequence of I/Os performed by such a transformation, the probability that Bob can correctly guess whether Alice has performed (the transformed version of) σ_1 or σ_2 is more than $1/2$ by at most $1/N^\alpha$ or a negligible amount, where $\alpha \leq 1$ is a constant¹ that represents a trade-off between efficiency and degree of obfuscation.

Note that N is used above in both the upper bound on the size of Alice’s set and also in the probability of Bob correctly distinguishing between two of her possible access sequences.

3. THE BUFFER SHUFFLE METHOD

One of the key techniques in our solutions is the use of oblivious shuffling. The input to any *shuffle* operation is a set, A , of N items. Because of the inclusion of the `getRange` operation in the server’s API, we can view the items in A as being ordered by their keys. Moreover, this functionality also allows us to access a contiguous run of M such items, starting from a given key. The output of a shuffle is a reordering of the items in A with replacement keys, so that all permutations are equally likely. During a shuffle, the server, Bob, can observe Alice read (and remove) M of the items he is storing for her, and then write back M more items, which provides some degree of obfuscation of how the items in these read and write groups are correlated. An additional desire for the output of a shuffle is that, for any item x in the input, the adversary should be able to correlate x with any item y in the output only with probability that

¹We assume $L \ll N^\alpha$ in this case.

is very close to $1/N$ (which is what he would get from a random guess).

During such a shuffle, we assume that Alice is wrapping each of her key-value pairs, (k, v) , as $(k', (k, v))$, where k' is the new key that is chosen to obfuscate k . Indeed, it is likely that in each round of communication that Alice makes she will take a wrapped (input) pair, (k', X) , and map it to a new (output) pair, (k'', X') , where the X' is assumed to be a re-encryption of X . The challenge is to define an encoding strategy for the k' and k'' wrapper keys so that it is difficult for the adversary to correlate inputs and outputs.

3.1 Theoretical Choice: Oblivious Sorting

One way to do this is to assign each item a random key from a very large universe, which is separate and distinct from the key that is a part of this key-value pair, and obliviously sort [9] the items by these keys. That is, we can wrap each key-value pair, (k, v) , as $(k', (k, v))$, where k' is the new random key, and then wrap these wrapped pairs in a way that allows us to implement an oblivious sorting algorithm in the OS model based on comparisons involving the k' keys. Specifically, during this sorting process, we would further wrap each wrapped item, $(k', (k, v))$, as $(\alpha, (k', (k, v)))$, where α is an address or index used in the oblivious sorting algorithm. So as to distinguish such keys even further, Alice can also add a prefix to each such α , such as “Addr:” or “Addr*i*”, where i is a counter (which could, for instance, be counting the steps in Alice’s sorting algorithm). Using such addresses as “keys” allows Alice to consider Bob’s storage as if it were an array or the memory of a RAM. She can then use this scheme to simulate an oblivious sorting algorithm.

If the randomly assigned keys are distinct, which will occur with very high probability, then this achieves the desired goal. And even if the new keys are not distinct, we can repeat this operation until we get a set of distinct new keys without revealing any data-dependent information to the server.

From a theoretical perspective, it is hard to beat this solution. It is well-known, for instance, that shuffling by sorting items via randomly-assigned keys generates a random permutation such that all permutations are equally likely (e.g., see [13]). In addition, since the means to go from the input to the output is data-oblivious with respect to the I/Os (simulated using the address keys), the server who is watching the inputs and outputs cannot correlate any set of values. That is, independent of the set of I/Os, any input item, x , at the beginning of the sort can be mapped to any output item, y , at the end. Thus, for any item x in the input, the adversary can correlate x with any item y in the output with probability exactly $1/N$. Finally, we can use the external-memory deterministic oblivious-sorting algorithm of Goodrich and Mitzenmacher [9], for instance, so as to use messages of size $O(M^{1/2})$, which will result in an algorithm that sorts in $O((N/M) \log_{\sqrt{M}}(N/M)) = O((N/M)c^2)$ I/Os. That is, such a sorting algorithm uses a constant amortized number of I/Os per item.

Although oblivious sorting algorithm offers hardness of correlation of $1/N$ between the location of an item in the input and its new location in the output sequence, it requires a fairly costly overhead, as the constant factors and details of this algorithm are somewhat nontrivial. Thus, it would be nice in applications that don’t necessarily require perfectly

oblivious shuffling to have a simple substitute that could be fast and effective in practice.

3.2 The Buffer Shuffle Algorithm

So, ideally, we would like a different oblivious shuffle algorithm, whose goal is still to obviously permute the collection, A , of N values, but with a simpler algorithm. The *buffer-shuffle* algorithm is such an alternative:

1. Perform a scan of A , M numbers at a time. With each step, we read in M wrapped items from A , each of the form $(k', (k, v))$, and randomly permute them in Alice’s local memory.
2. We then generate a new random key, k'' , for each such wrapped item, $(k', (k, v))$, in this group, and we output all those new key-value pairs back to the server.
3. We then repeat this operation with the next M numbers, and so on, until Alice has made a pass through all the numbers in A .

Call this a single *pass*. After such a pass, we can view the new keys as being sorted at the server (as observed above, by the properties of the OS model). Thus, we can perform another pass over these new key-value pairs, generating an even newer set of wrapped key-value pairs. (This functionality is supported by range queries, for example, so there is little overhead for the client in implementing each such pass.) Finally, we repeat this process for some constant, b , times, which is established in our analysis below. This is the *buffer-shuffle* algorithm.

3.3 Buffer-Shuffle Analysis

To analyze the *buffer-shuffle* algorithm, we first focus on the following goal: we show that with probability $1 - o(1)$ after four passes, one cannot guess the location of an initial key-value pair with probability greater than $1/N + o(1/N)$, assuming $M = N^{1/3}$, where N is the number of items being permuted. After we prove this, we discuss how the proof extends to obtain improved probabilities of success and tighter bounds on the probability of tracking so that they are closer to $1/N$, as well as how to extend to cases where $M = N^{1/k}$ for integers $k \geq 3$.

We think of the keys at the beginning of each pass as being in key-sorted order, in $N^{2/3}$ groups of size $N^{1/3}$. Let $P_{i,j}$ be the perceived probability that after i passes the key we are tracking is in group j , according to the view of the tracker, Bob. Note that Bob can see, for each group on each pass, the set of keys that correspond to that group at the beginning and end of the pass, and use that to compute values $P_{i,j}$ corresponding to their perceived probabilities. Without loss of generality, we consider tracking the first key, so $P_{0,1} = 1$.

Our goal will be to show that $P_{i,j} = N^{-2/3} + o(N^{-2/3})$, for $i = 3$ and for all j , conditioned on some events regarding the random assignment of keys at each pass. The events we condition on will hold with probability $1 - o(1)$. This yields that the key being tracked appears to a tracker to be (up to lower order terms) in a group chosen uniformly at random. As the key values in each group are randomized at the next pass, this will leave the tracker with a probability only $1/N + o(1/N)$ of guessing the item, again assuming the bad $o(1)$ events do not occur.

Let $X_{i,k,j}$ be the number of keys that go from group k to group j in pass i . One can quickly check that $X_{i,k,j}$ is 0 with

probability near 1. Indeed, the probability that $X_{i,k,j} = c$ is bounded above by

$$\binom{N^{1/3}}{c} (N^{-2/3})^c = O(N^{-c/3}).$$

We have the recurrence

$$P_{i,j} = \sum_k P_{i-1,k} \frac{X_{i,k,j}}{N^{1/3}}.$$

The explanation for this recurrence is straightforward. The probability that the key being tracked is in the j th group after pass i is the sum over all groups k of the probability that the key was in group k , given by $P_{i-1,k}$, times the probability that the corresponding new key was mapped to group j , which is $X_{i,k,j}/N^{1/3}$.

Our goal now is to show that over successive passes that as long as the values $X_{i,k,j}$ behave nicely, the $P_{i,j}$ will quickly converge to roughly $N^{-2/3}$. We sketch an argument for probability $1 - o(1)$ and then comment on how the $o(1)$ term can be reduced to any inverse polynomial probability in a constant number of passes. Our main approach is to note that bounding the $X_{i,k,j}$ corresponds to a type of balls and bins problem, in which case negative dependence can be applied to get a suitable concentration result via a basic Chernoff bound.

THEOREM 1. *When $M = N^{1/3}$, after four passes, Bob cannot guess the location of an initial item with probability greater than $1/N + o(1/N)$.*

PROOF SKETCH: We consider the four passes in succession.

- Pass 1: It is easy to check that with probability $1 - o(1)$ (using union bounds and the binomial distribution to bound the number of keys from group 1 that land in every other group) there are up to $c \log N$ groups for which $X_{1,1,j} = 2$ and 0 groups for which $X_{1,1,j} = 3$. Thus, there are $N^{1/3} - O(\log N)$ groups for which $P_{1,j} = N^{-1/3}$ and $O(\log N)$ groups for which $P_{1,j} = 2N^{-1/3}$.

- Pass 2: Our interpretation here (and going forward) is that each key in group j after pass $i - 1$ has a "weight" $P_{i-1,j}/N^{1/3}$ that it gives to the group it lands in in pass i ; the sum of weights in a group then yields $P_{i,j}$.

With this interpretation, with probability $1 - o(1)$, there are $N^{2/3} - o(N^{2/3})$ keys at the end of pass 1 with positive weight (of either $N^{-2/3}$ or $2N^{-2/3}$). These keys are rerandomized, so at the end of pass 2, the number of keys with positive weight in a given bucket j is expected to be constant, and again simple binomial and union bounds imply that the maximum number of keys with positive weight in any bucket is at most $c \log N$ with probability $1 - o(1)$. Indeed, one can further show at the end of pass 2 that the number of groups j with $P_{2,j} > 0$ must be at least $\Omega(N^{2/3})$ with probability $1 - o(1)$; this follows from the fact that, for example, if Y_j is the 0/1 random variable that represents whether a group j received at least one weighted key, then $E[Y_j] > 1/2$, and the Y_j are negatively associated, so Chernoff bounds apply. (See, for example, Chapter 3 of [7].)

- Pass 3: Conditioned on the $1 - o(1)$ events from the first two passes, at the end of the second pass there are $\Omega(N)$ keys with positive weight going into pass 3, and the possible weight values for each key are bounded by $(c' \log N)/N$ for some constant c' . The expected weight for each group after pass 3 is obviously $N^{-2/3}$. The weights of the keys within a group are negatively associated, so we can apply a Chernoff bound to the weight associated with each group, noting that to apply the Chernoff bound we should re-scale so the range of the weights is $[0, 1]$. Consider the first group, and let Z_i be the weight of the i th keys in the first group (scaled by multiplying the weight by $N/(c' \log N)$). Let $Z = \sum_{i=1}^{N^{2/3}} Z_i$. Then

$$\Pr \left(\left| Z - \frac{N^{1/3}}{c' \log N} \right| \geq N^{1/5} \right) \leq e^{-2N^{1/15}}.$$

Or, rescaling back, the weight in the first group is within $N^{-4/5}/(c' \log N)$ of $N^{-2/3}$ with high probability, and a union bound suffices to show that this is the same for all groups.

- Pass 4: After pass 3, with probability $1 - o(1)$ each key has weight $1/N + o(1/N)$, and so after randomizing, assuming the events of probability $1 - o(1)$ all hold, the probability that any key is the original one being tracked from Bob's point of view is $1/N + o(1/N)$. \square

We remark that the $o(1)$ failure probability can be reduced to any inverse polynomial by a combination of choosing constant c and c' to be sufficiently high, and/or repeating passes a (constant) number of times to reduce the probability of the bad events. (For example, if Pass 1, fails with probability p , repeating it a times reduces the failure probability to p^a ; the $o(1)$ failure probabilities are all inverse polynomial in N in the proof above.)

Similarly, one can ensure that the probability that any key is the tracked key to $1/N + o(1/N^a)$ for any constant a by increasing the number of passes further, but still keeping the number of passes constant. Specifically, note that we have shown that after the first four passes, with high probability the weight of each key bounded between $N^{-1} - N^{-j}$ and $N^{-1} + N^{-j}$ for some $j > 1$, and the total key weight is 1. We re-center the weights around $N^{-1} - N^{-j}$ and multiply them by N^{j-1} ; now the new reweighted weights sum to 1. We can now re-apply above the argument; after four passes we know that reweighted weights for each key will again be $N^{-1} - N^{-j}$ and $N^{-1} + N^{-j}$. Undoing the rescaling, this means the weights for the keys are now bounded $N^{-1} - N^{-j}$ and $N^{-1} + N^{1-2j}$, and we can continue in this fashion to obtain the desired closeness to $1/N$.

Finally, we note that the assumption that we can read in $N^{1/3}$ key-value pairs and assign them new random key values can be reduced to $N^{1/j}$ pairs for any $j \geq 3$. We sketch the proof. Each step, as in the original proof, holds with probability $1 - o(1)$.

In this case we have $N^{(j-1)/j}$ groups. In the first pass, the weight from the shuffling is spread to $\Omega(N^{2/j})$ key-value pairs, following the same reasoning as for Pass 1 above. Indeed, we can continue this argument; in the next pass, where the weight will spread to $\Omega(N^{3/j})$ key-value pairs, and so on, until after $j - 2$ passes there are $\Omega(N^{(j-1)/j})$

keys with non-zero weight with high probability, with one small modification in the analysis: at each pass, we can ensure that each group has less than j weighted keys with high probability.

Then, following the same argument as in Pass 2 above, one can show that after the following pass $\Omega(N)$ keys have non-zero weight, and the maximum weight is bounded above by $(c' \log N)/N$ for some constant c' . Applying the Chernoff bound argument for Pass 3 above to the next pass we find that the weight within each of the $N^{(j-1)/j}$ groups is equal to $1/N + o(1/N)$ after this pass, and again this suffices by the recurrence to show that at most one more pass is necessary for each key-value pair to have weight $1/N + o(1/N)$.

4. A SQUARE ROOT SOLUTION

As is a common practice in ORAM simulation papers, starting with the work of Goldreich and Ostrovsky [8], before we give our more sophisticated solutions to the oblivious storage problem, we first give a simple *square-root* solution. Our general solution is an inductive extension of this solution, so the square-root solution also serves to form a basis for this induction.

In this square-root solution, we assume $M \geq N^{1/2}$. Thus, Alice has a local memory of size at least $N^{1/2}$, and she and Bob can exchange a message of size up to at least $N^{1/2}$ in a single I/O. In addition, we assume that this solution provides an API for performing oblivious dictionary operations where every $\text{get}(k)$ or $\text{put}(k, v)$ operation is guaranteed to be for a key k that is contained in the set, S , that Alice is outsourcing to Bob. That is, we give a miss-intolerant solution to the oblivious storage problem.

Our solution is based on the observation that we can view Alice’s memory as a miss-tolerant solution to the OS problem. That is, Alice can store $O(M)$ items in her private memory in some dictionary data structure, and each time she queries her memory for a key k she can determine if k is present without leaking any data-dependent information to Bob.

4.1 Construction

Let us assume we have a miss-tolerant dictionary, $D(N)$, that provides a solution to the OS problem that works for sets up to size N , with at most $O(1)$ amortized number of I/Os of size at most N per access. Certainly, a dictionary stored in Alice’s internal memory suffices for this purpose (and it, in fact, doesn’t even need any I/Os per access), for the case when N is at most M , the size of Alice’s memory.

The memory organization of our solution, $B(N)$, we describe here, consists of two caches:

- A cache, C_0 , which is of size M and is implemented using an instance of a $D(M)$ solution.
- A cache, C_1 , which is of size $N + M$, which is stored as a dictionary of key-value pairs using Bob’s storage.

The extra M space in C_1 is for storing M “dummy” items, which have keys indexed from a range that is outside of the universe used for S , which we denote as $-1, -2, \dots, -M$. Let S' denote the set of N items from S , plus items with these dummy keys (along with null values), minus any items in C_0 . Initially, C_0 is empty and C_1 stores the entire set S plus the M items with dummy keys. For the sake of obliviousness, each item, (k, v) , in the set S' is mapped to a

substitute key by a nonce pseudo-random hash function, h_r , where r is a random number chosen at the time Alice asks Bob to build (or rebuild) his dictionary. In addition, each value v is encrypted as $E_K(v)$, with a secret key, K , known only to Alice. Thus, each item (k, v) in S' is stored by Bob as the key-value pair $(h_r(k), E_K(v))$.

To perform an access, either for a $\text{get}(k)$ or $\text{put}(k, v)$, Alice first performs a lookup for k in C_0 , using its technology for achieving obliviousness. If she does not find an item with key k (as she won’t initially), then she requests the item from Bob by issuing a request, $\text{get}(h_r(k))$, to him. Note that, since k is a key in S , and it is not in Alice’s cache, $h_r(k)$ is a key in S' , by the fact that we are constructing a miss-intolerant OS solution. Thus, there will be an item returned from this request. From this returned item, $(h_r(k), E_K(v))$, Alice decrypts the value, v , and stores item (k, v) in C_0 , possibly changing v for a put operation. Then she asks Bob to remove the item with key $h_r(k)$ from S' .

If, on the other hand, in performing an access for a key k , Alice finds a matching item for k in C_0 , then she uses that item and she issues a dummy request to Bob by asking him to perform a $\text{get}(h_r(-j))$ operation, where j is a counter she keeps in her local memory for the next dummy key. In this case, she inserts this dummy item into C_0 and she asks Bob to remove the item with key $h_r(-j)$ from S' . Therefore, from Bob’s perspective, Alice is always requesting a random key for an item in S' and then immediately removing that item. Indeed, her behavior is always that of doing a get from C_0 , a get from C_1 , a remove from C_1 , and then a put in C_0 .

After Alice has performed M accesses, C_0 will be holding M items, which is its capacity. So she pauses her performance of accesses at this time and enters a *rebuilding* phase. In this phase, she rebuilds a new version of the dictionary that is being maintained by Bob.

The new set to be maintained by Bob is the current S' unioned with the items in C_0 (including the dummy items). So Alice resets her counter, j , back to 1. She then performs an oblivious shuffle of the set $S'' = C_0 \cup S'$. This oblivious shuffle is performed either with an external-memory sorting algorithm [9] or with the buffer-shuffle method described above, depending, respectively, on whether Alice desires perfect obscurity or if she can tolerate a small amount of information leakage, as quantified above. Finally, after this random shuffle completes, Alice chooses a new random nonce, r , for her pseudo-random function, h_r . She then makes one more pass over the set of items (which are masked and encrypted) now stored by Bob (using getRange operations as in the buffer-shuffle method), and she maps each item (k, v) to the pair $(h_r(k), E_K(v))$ and asks Bob to store this item in his memory. This begins a new “epoch” for Alice to then use for the next M accesses that she needs to make.

4.2 Analysis

Let us consider an amortized analysis of this solution. For the sake of amortization, we charge each of the previous M accesses for the effort in performing a rebuild. Since such a rebuild takes $O(N/M)$ I/Os, provided $M \geq N^{1/c}$, for some constant $c \geq 2$, this means we will charge $O(N/M^2)$ I/Os to each of these previous accesses. Thus, we have the following.

LEMMA 2. *Suppose we are given a miss-tolerant OS solution, $D(N)$, which achieves $O(1)$ amortized I/Os per access for messages of up to size M , when applied to a set of size N/M . Then we can use this as a component, $D(N/M)$,*

of a miss-intolerant OS solution, $B(N)$, that achieves $O(1)$ amortized I/Os per access for messages of size up to $M \geq N^{1/c}$, for some constant $c \geq 2$. The private memory required for this solution is $O(M)$.

PROOF SKETCH: The number of amortized I/Os will be $O(1)$ per access, from $D(N)$. The total number of I/Os needed to do a rebuild is $O(N/M)$, assuming M is at least $N^{1/c}$, for some constant $c \geq 2$. There will be N/M items that are moved in this case, which is equal to the number of previous accesses; hence, the amortized number of I/Os will be $O(1)$ per access. The performance bounds follow immediately from the above discussion and the simple charging scheme we used for the sake of an amortized analysis. For the proof of security, note that each access that Alice makes to the dictionary S' will either be for a real item or a dummy element. Either way, Alice will make exactly N/M requests before she rebuilds this dictionary stored with Bob. Moreover, from the adversary's perspective, every request is to an independent uniform random key, which is then immediately removed and never accessed again. Therefore, the adversary cannot distinguish between actual requests and dummy requests. In addition, he cannot correlate any request from a previous epoch, since Alice randomly shuffles the set of items and uses a new pseudo-random function with each epoch. \square

By then choosing the messages size, M , appropriately, we obtain the following result.

THEOREM 3. *The square-root solution achieves $O(1)$ amortized I/Os for each data access, allowing a client, Alice, to obliviously store N items in a miss-intolerant way with an honest-but-curious server, Bob, using messages of size $M = N^{1/2}$ and local memory of size $2M$. The probability that this simulation fails to be oblivious is exponentially small for a polynomial-length access sequence, if oblivious sorting is used for shuffling, and polynomially small if buffer-shuffling is used.*

PROOF SKETCH: Plugging $M = N^{1/2}$ into Lemma 2 gives us the complexity bound. The obliviousness follows from the fact that if she has an internal memory of size $M = N^{1/2}$, then Alice can easily implement a miss-tolerant OS solution in her internal memory, which achieves the conditions of the $D(M)$ solution needed for the cache C_0 . \square

Note that the constant factor in the amortized I/O overhead in the square-root solution is quite small.

Note, in addition, that by the obliviousness definition in the OS model, it does not matter how many accesses Alice makes to the solution, $B(N)$, provided that her number of accesses are not self-revealing of her data items themselves.²

5. MISS-TOLERANCE

An important functionality that is lacking from the square-root solution is that it does not allow for accesses to items that are not in the set S . That is, it is a miss-intolerant OS solution. Nevertheless, we can leverage the square-root solution to allow for such accesses in an oblivious way, by using a hashing scheme.

²An access sequence would be self-revealing, for example, if Alice reads a value and then performs a number of accesses equal to this value.

5.1 Review of Cuckoo Hashing

The main idea behind this extension is to use a miss-intolerant solution to obviously implement a *cuckoo hashing* scheme [16]. In cuckoo hashing, we have two hash tables T_1 and T_2 and two associated pseudo-random hash functions, f_1 and f_2 . An item (k, v) is stored at $T_1[f_1(k)]$ or $T_2[f_2(k)]$. When inserting item (k, v) , we add it to $T_1[f_1(k)]$. If that cell is occupied by another item, (\hat{k}, \hat{v}) , we evict that item and place it in $T_2[f_2(\hat{k})]$. Again, we may need to evict an item. This sequence of evictions continues until we put an item into a previously-empty cell or we detect an infinite loop (in which case we rehash all the items). Cuckoo hashing achieves $O(1)$ expected time for all operations with high probability. This probability can be boosted even higher to $1 - 1/n^s$ by using a small cache, known as a *stash* [12], of size s to hold items that would have otherwise caused infinite insertion loops. With some additional effort (e.g., see [3]), cuckoo hashing can be de-amortized to achieve $O(1)$ memory accesses, with very high probability, for insert, remove, and lookup operations.

In most real-world OS solutions, standard cuckoo hashing should suffice for our purposes. But, to avoid inadvertent data leakage and ensure high-probability performance bounds, let us assume we will be using de-amortized cuckoo hashing.

5.2 Implementing Cuckoo Hashing with a Miss-Intolerant OS Solution

Let us assume we have a miss-intolerant solution, $B(N)$, to the OS problem, which achieves a constant I/O complexity for accesses, using messages of size M .

A standard or de-amortized cuckoo hashing scheme provides an interface for performing $\text{get}(k)$ and $\text{put}(k, v)$ operations, so that get operations are miss-tolerant. These operations are implemented using pseudo-random hash functions in the random access memory (RAM) model, i.e., using a collection of memory cells, where each such cell is uniquely identified with an index i . To implement such a scheme using solution $B(N)$, we simulate a read of cell i with $\text{get}(i)$ operation and we simulate a write of x to cell i with $\text{put}(i, x)$. Thus, each access using $B(N)$ is guaranteed to return an item, namely a cell (i, x) in the memory (tables and variables) used to implement the cuckoo-hashing scheme. Thus, whenever we access a cell with index i , we actually perform a request for (an encryption of) this cell's contents using the obliviousness mechanism provided by $B(N)$.

That is, to implement a standard or de-amortized cuckoo hashing scheme using $B(N)$, we assume now that every (non-dummy) key in Alice's simulation is an index in the memory used to implement the hashing scheme. Thus, each access is guaranteed to return an item. Moreover, because inserts, removals, and lookups achieve a constant number of memory accesses, with very high probability, in a de-amortized cuckoo-hashing scheme (or with constant expected-time performance in a standard cuckoo hashing scheme), then each operation in a simulation of de-amortized cuckoo hashing in $B(N)$ involves a constant number of accesses with very high probability. Therefore, using a de-amortized cuckoo-hashing scheme, we have the following result.

THEOREM 4. *Given a miss-intolerant OS solution, $B(N)$, that achieves $O(1)$ amortized I/O performance with messages of size M and achieves confidentiality and hardness*

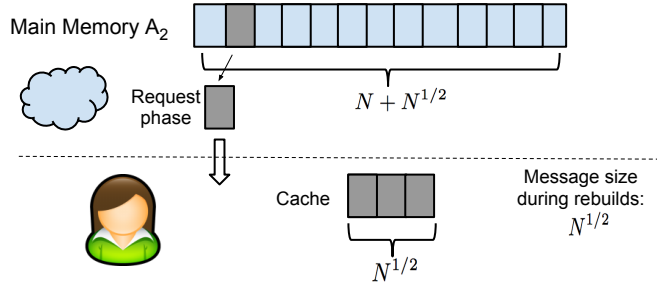

Figure 1: Memory layout for $c = 2$. The locations accessed by the user are visualized as gray-filled rectangles.

of correlation, we can implement a miss-tolerant solution, $D(N)$, that achieves $O(1)$ amortized I/O performance and also achieves confidentiality and hardness of correlation.

PROOF SKETCH: The result follows from using a cuckoo hashing interface to hide accesses to $B(N)$ for items that are not there. The hardness of correlation of the resulting OS solution, $D(N)$, depends on the shuffle algorithm used during the rebuild phase of $B(N)$. \square

A standard cuckoo-hashing scheme yields instead the following result.

THEOREM 5. *Given a miss-intolerant OS solution, $B(N)$, that achieves expected $O(1)$ amortized I/O performance, with messages of size M , we can implement a miss-tolerant solution, $D(N)$, that achieves $O(1)$ expected amortized I/O performance and also achieves confidentiality and hardness of correlation.*

Our use of cuckoo hashing in the above construction is quite different, by the way, than previous uses of cuckoo-hashing for oblivious RAM simulation [9, 11, 14]. In these other papers, the server, Bob, gets to see the actual indexes and memory addresses used in the cuckoo hashing scheme. Thus, the adversary in these other schemes can see where items are placed in cuckoo tables (unless their construction is itself oblivious) and when and where they are removed; hence, special care must be taken to construct and use the cuckoo tables in an oblivious way. In our scheme, the locations in the cuckoo-hashing scheme are instead obfuscated because they are themselves built on top of an OS solution.

Also, in previous schemes, cuckoo tables were chosen for the reason that, once items are inserted, their locations are determined by pseudo-random functions. Here, cuckoo tables are used only for the fact that they have constant-time insert, remove, and lookup operations, which holds with very high probability for de-amortized cuckoo tables and as an expected-time bound for standard cuckoo tables.

6. AN INDUCTIVE SOLUTION

The miss-tolerant square-root method given in Section 5 provides a solution of the oblivious storage problem with amortized constant I/O performance for each access, but requires Alice to have a local memory of size $2N^{1/2}$ and messages to be of size $N^{1/2}$ during the rebuilding phase (although constant-size messages are exchanged during the

access phase). In this section, we show how to recursively apply this method to create a more efficient solution.

For an integer $c \geq 2$, let $D_c(N)$ denote a miss-intolerant oblivious storage solution that has the following properties:

1. It supports a dictionary of N items.
2. It requires local memory of size $cN^{1/c}$ at the client.
3. It uses messages of size $N^{1/c}$.
4. It executes $O(1)$ amortized I/Os per operation (each get or put), where the constant factor in this bound depends on the constant c .
5. It achieves confidentiality and hardness of correlation.

Note that using this notation, the square-root method derived in Section 5 using cuckoo hashing is a $D_2(N)$ oblivious storage solution.

6.1 The Inductive Construction

For our inductive construction, for $c \geq 3$, we assume the existence of a oblivious storage solution $D_{c-1}(N')$. We can use this to build a miss-tolerant oblivious storage solution, $D_c(N)$, using message size $M = N^{1/c}$ as follows:

1. Use the construction of Lemma 2 to build a miss-intolerant OS solution, $B_c(N)$, from $D_{c-1}(N/M)$. This solution has $O(1)$ amortized I/Os per access, with very high probability, using messages of size M and private memory of size $O(M)$ since $D_{c-1}(N/M)$ uses memory of size

$$\left(\frac{N}{M}\right)^{\frac{1}{c-1}} = N^{\frac{1-\frac{1}{c}}{c-1}} = N^{\frac{1}{c}} = M.$$

2. Use the construction of Theorem 4 to take the miss-intolerant solution, $B_c(N)$, and convert it to a miss-tolerant solution. This solution uses an $O(1)$ amortized number of I/Os, with high probability, using messages of size $M = N^{1/c}$, and it has the performance bounds necessary to be denoted as $D_c(N)$.

An intuition of our construction is as follows. We number each level of the construction such that c is the top most and 2 is the lowest level, hence there are $c - 1$ levels. The top level, c , consists of the main memory A_c of size $O(N)$ and uses the rest of the construction as a cache for $O(N/M)$ items which we referred to as $B_c(N)$. This cache is the

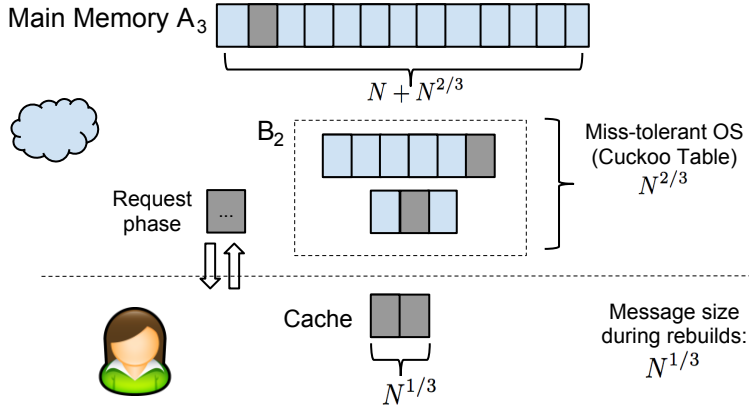

Figure 2: Memory layout for $c = 3$. Oblivious solution B_2 and the cache are both used to buffer the items that have been accessed from A_3 . B_2 is rebuilt every time the cache is full while A_3 is rebuilt whenever B_2 becomes full.

beginning of our inductive construction and, hence, itself is an OS over $O(N/M)$ items. The inductive construction continues such that level i contains a miss-tolerant data structure A_i and levels $(i - 1), \dots, 2$ are used as a cache of level i . The construction terminates when we reach level 2 since the size of the cache at level 2 is equal to the message size M which Alice can request using a single access or store in her own memory. We give an illustration of our construction for $c = 2$ and $c = 3$ in Figures 1 and 2, respectively.

THEOREM 6. *The above construction results in an oblivious storage solution, $D_c(N)$, that is miss-tolerant, supports a dictionary of N items, requires client-side local memory of size $cN^{1/c}$, uses messages of size $N^{1/c}$, achieves an amortized $O(1)$ number of I/Os for each `get` and `put` operation, where the constant factor in this bound depends on the constant $c \geq 2$. In addition, this method achieves confidentiality and hardness of correlation.*

PROOF SKETCH: The complexity of the solution follows from its inductive construction. A request for an item in $D_c(N)$ requires accesses to $c - 1$ levels where each level i is a miss-intolerant oblivious solution, $D_i(N/M^{c-i})$, with a cuckoo hashing interface. Hence, oblivious access to each level incurs $O(1)$ amortized I/Os and $O(c)$ I/Os in total for $D_c(N)$.

The confidentiality and hardness of correlation of $D_c(N)$ relies on the fact that accesses to each level are made through an oblivious solution which guarantees these properties. \square

7. PERFORMANCE

We have built a system prototype of our oblivious storage method to estimate the practical performance of our solution and compare it with that of other OS solutions. In our simulation, we record the number of access operations to the storage server for every original data request by the client. Our prototype specifically simulates the use of Amazon S3 as the provider of remote storage, based on their current API. In particular, we make use of operations `get`,

`put`, `copy` and `delete` in the Amazon S3 API. Since Amazon S3 does not support range queries, we substitute operation `getRange(i_1, i_2, m)` of our OS model with m concurrent `get` requests, which could be issued by parallel threads running at the client to minimize latency. Operation `removeRange` is handled similarly with concurrent `delete` operations. We have run the simulation for two configurations of our OS solution, $c = 2$ and $c = 3$. For $c = 3$ we use standard cuckoo hashing for second level cache, B_2 . We consider two item sizes, 1KB and 64KB. The size (number of items) of the messages exchanged by the client and server is $M = N^{1/c}$ where N , the number of items in the outsourced data set, varies from 10^4 to 10^6 .

7.1 Storage Overhead

The overall storage space (no. of items) used by our solution on the server is $N + 2 \sum_{i=1}^{c-2} N^{(c-i)/c}$, i.e. $N + N^{1/2}$ for $c = 2$ and $N + 2N^{2/3}$ for $c = 3$. For $c = 2$, our method has storage overhead comparable to that of Boneh *et al.* [4] and much smaller than the space used by other approaches.

7.2 Access Overhead

In Table 2, we show the number of I/Os to the remote data repository during the oblivious simulation of N requests. Recall that the number of I/Os is the number of round trips the simulation makes. Thus, the `getRange` operation is counted as one I/O. In the table, column Minimum gives the number of I/Os performed by Alice to receive the requested item. The remaining I/Os are performed for reshuffling. For $c = 2$, this number is 2 since the client sends a `get` request to either get an actual item or a dummy item, followed by a `delete` request. For $c = 3$, this number is slightly higher since Alice needs to simulate accesses to a cuckoo table through an OS interface. We compare our I/O overhead and the total amount of data transferred with that of Boneh *et al.* [4]. They also achieve $O(1)$ request overhead and exchange messages of size $M = N^{1/2}$ with the server. Our new buffer shuffle algorithm makes our approach more efficient in terms of data transfer and the number of operations the user makes to the server.

7.3 Time Overhead

Given the trace of user’s operations during the simulation and empirical measurements of round trip times of operations on the Amazon S3 system (see Table 4), we estimate the access latency of our OS solutions in Tables 5 and 6 for 1KB items and 64KB items, respectively.

7.4 Cost Overhead

Finally, we provide estimates of the monetary cost of OS our solution in Table 5 using the pricing scheme of Amazon S3 (see Table 4 and <http://aws.amazon.com/s3/pricing/>³). Since our results outperform other approaches in terms of number of accesses to the server we expect that our monetary cost will be also lower.

Acknowledgments

This research was supported in part by the National Science Foundation under grants 0721491, 0915922, 0953071, 0964473, 1011840, and 1012060, by NetApp, Inc., and by the Center for Geometric Computing and the Kanellakis Fellowship at Brown University.

References

- [1] M. Ajtai. Oblivious RAMs without cryptographic assumptions. In *Proc. ACM Symp. on Theory of Computing (STOC)*, pages 181–190. ACM, 2010.
- [2] Amazon. Amazon S3 Service. <http://aws.amazon.com/s3-s1a/>.
- [3] Y. Arbitman, M. Naor, and G. Segev. De-amortized cuckoo hashing: Provable worst-case performance and experimental results. In *Proc. Int. Conf. Automata, Languages and Programming (ICALP)*, pages 107–118. Springer, 2009.
- [4] D. Boneh, D. Mazières, and R. A. Popa. Remote oblivious storage: Making oblivious RAM practical. Technical report, CSAIL, MIT, 2011. <http://dSPACE.mit.edu/handle/1721.1/62006>.
- [5] S. Chen, R. Wang, X. Wang, and K. Zhang. Side-channel leaks in Web applications: a reality today, a challenge tomorrow. In *Proc. IEEE Symp. on Security and Privacy*, pages 191–206, 2010.
- [6] I. Damgård, S. Meldgaard, and J. B. Nielsen. Perfectly secure oblivious RAM without random oracles. In *Proc. Theory of Cryptography Conference (TCC)*, pages 144–163, 2011.
- [7] D. Dubhashi and A. Panconesi. *Concentration of Measure for the Analysis of Randomized Algorithms*. Cambridge University Press, New York, NY, USA, 2009.
- [8] O. Goldreich and R. Ostrovsky. Software protection and simulation on oblivious RAMs. *J. ACM*, 43(3):431–473, 1996.
- [9] M. T. Goodrich and M. Mitzenmacher. Privacy-preserving access of outsourced data via oblivious RAM simulation. In *Proc. Int. Colloq. on Automata, Languages and Programming (ICALP)*, pages 576–587, 2011.
- [10] M. T. Goodrich, M. Mitzenmacher, O. Ohrimenko, and R. Tamassia. Oblivious RAM simulation with efficient worst-case access overhead. In *Proc. ACM Workshop on Cloud Computing Security (CCSW)*, pages 95–100, 2011.
- [11] M. T. Goodrich, M. Mitzenmacher, O. Ohrimenko, and R. Tamassia. Privacy-preserving group data access via stateless oblivious RAM simulation. In *Proc. ACM-SIAM Symp. on Discrete Algorithms (SODA)*, 2012. To appear. Preliminary version in <http://arxiv.org/abs/1105.4125>.
- [12] A. Kirsch, M. Mitzenmacher, and U. Wieder. More robust hashing: cuckoo hashing with a stash. *SIAM J. Comput.*, 39:1543–1561, 2009.
- [13] D. E. Knuth. *Seminumerical Algorithms*, volume 2 of *The Art of Computer Programming*. Addison-Wesley, Reading, MA, 3rd edition, 1998.
- [14] E. Kushilevitz, S. Lu, and R. Ostrovsky. On the (in)security of hash-based oblivious RAM and a new balancing scheme. In *Proc. ACM-SIAM Symp. on Discrete Algorithms (SODA)*, 2012. To appear. Preliminary version in <http://eprint.iacr.org/2011/327>.
- [15] Microsoft Corp. Windows Azure. <http://www.microsoft.com/windowsazure>.
- [16] R. Pagh and F. Rodler. Cuckoo hashing. *Journal of Algorithms*, 52:122–144, 2004.
- [17] B. Pinkas and T. Reinman. Oblivious RAM revisited. In T. Rabin, editor, *Advances in Cryptology (CRYPTO)*, volume 6223 of *LNCS*, pages 502–519. Springer, 2010.
- [18] N. Pippenger and M. J. Fischer. Relations among complexity measures. *J. ACM*, 26(2):361–381, 1979.
- [19] E. Shi, T.-H. H. Chan, E. Stefanov, and M. Li. Oblivious RAM with $O((\log N)^3)$ worst-case cost. In *Proc. ASIACRYPT*, pages 197–214, 2011.
- [20] E. Stefanov, E. Shi, and D. Song. Towards Practical Oblivious RAM. In *Proc. Network and Distributed System Security Symposium (NDSS)*, 2012. To appear. Preliminary version in <http://arxiv.org/abs/1106.3652>.
- [21] J. S. Vitter. External sorting and permuting. In M.-Y. Kao, editor, *Encyclopedia of Algorithms*. Springer, 2008.
- [22] P. Williams and R. Sion. Usable PIR. In *Proc. Network and Distributed System Security Symposium (NDSS)*, 2008.
- [23] P. Williams, R. Sion, and B. Carbunar. Building castles out of mud: practical access pattern privacy and correctness on untrusted storage. In *ACM Conference on Computer and Communications Security (CCS)*, pages 139–148, 2008.

³Accessed on 9/21/2011

N	Minimum/Amortized	
	$M = N^{1/2}$	$M = N^{1/3}$
10,000	2/13	7/173
100,000	2/13	7/330
1,000,000	2/13	7/416

Table 2: Minimum and amortized number of I/Os to access one item in our OS solution for $c = 2$ and $c = 3$. We simulate a sequence of N accesses on a system that uses four passes of the buffer shuffle algorithm.

N	I/O Overhead and Data Transferred (#items)			
	Boneh <i>et al.</i> [4]		Our Method	
	Minimum	Amortized	Minimum	Amortized
10,000	3/9	$13/1.3 \times 10^3$	2/1	$13/1.1 \times 10^3$
100,000	3/10	$17/5.2 \times 10^3$	2/1	$13/3.5 \times 10^3$
1,000,000	3/12	$20/2 \times 10^4$	2/1	$13/1.1 \times 10^4$

Table 3: Minimum and amortized number of I/Os and number of items transferred to access one item. We compare our OS solution for $c = 2$ with that of [4] on a data set with 1KB items. In both solutions the message size is $M = N^{1/2}$ items.

Operation	Price	RTT (ms)	
		1KB	64KB
Get	\$0.01/10,000req	36	56
Put	\$0.01/1,000req	65	86
Copy	free	70	88
Delete	free	31	35

Table 4: Amazon S3's pricing scheme and empirical measurement of round trip time (RTT) for an operation issued by a client in Providence, Rhode Island to the Amazon S3 service (average of 300 runs).

N	$M = N^{1/2}$			$M = N^{1/3}$		
	Access Time		Total Cost	Access Time		Total Cost
	Minimum	Amortized		Minimum	Amortized	
10,000	67ms	500ms	\$55	400ms	8s	\$177
100,000	67ms	500ms	\$1,744	400ms	12s	\$7,262
1,000,000	67ms	500ms	\$55,066	400ms	18s	\$170,646

Table 5: Estimate of the access time per item and total monetary cost for accessing N items, each of size 1KB, stored on the Amazon S3 system using our OS method for $c = 2$ and $c = 3$.

N	$M = N^{1/2}$			$M = N^{1/3}$		
	Access Time		Total Cost	Access Time		Total Cost
	Minimum	Amortized		Minimum	Amortized	
10,000	91ms	800ms	\$55	500ms	12s	\$177
100,000	91ms	800ms	\$1,744	500ms	18s	\$7,262
1,000,000	91ms	800ms	\$55,066	500ms	24s	\$170,646

Table 6: Estimate of the access time per item and total monetary cost for accessing N items, each of size 64KB, stored on the Amazon S3 system using our OS method for $c = 2$ and $c = 3$.