

Student ID: _____

CS 151 Midterm

Name : _____ , _____
(Last Name) (First Name)

Student ID : _____

Signature : _____

Instructions:

1. Please verify that your paper contains **10 pages** including this cover.
2. Write down your Student-Id on the top of each page of this quiz.
3. This exam is **closed book**. No notes or other materials are permitted.
4. Total credits of this midterm are **55 points**.
5. To receive credit you must show your work clearly.
6. **For possible re-grade request make sure that your write clearly.**
7. Calculators are **NOT** allowed.

Student ID: _____

Q1: [ALU] [15 points]

We are going to design a 4-bit Arithmetic Unit (AU) with the following functional table:

M1	M0	Function Name	F(A,B)
0	0	Add A and B	A+B
0	1	Subtract B from A	A-B
1	0	Decrement A	A-1
1	1	Add A and 2*B and 2	A+2*B+2

A and B are two 4-bit binary numbers $a_3a_2a_1a_0$ and $b_3b_2b_1b_0$.

M1, M0 are the control inputs to this AU.

For doing this, the blocks labeled “Black Box” and CE (Carry Extender) in the following block diagram should be designed:

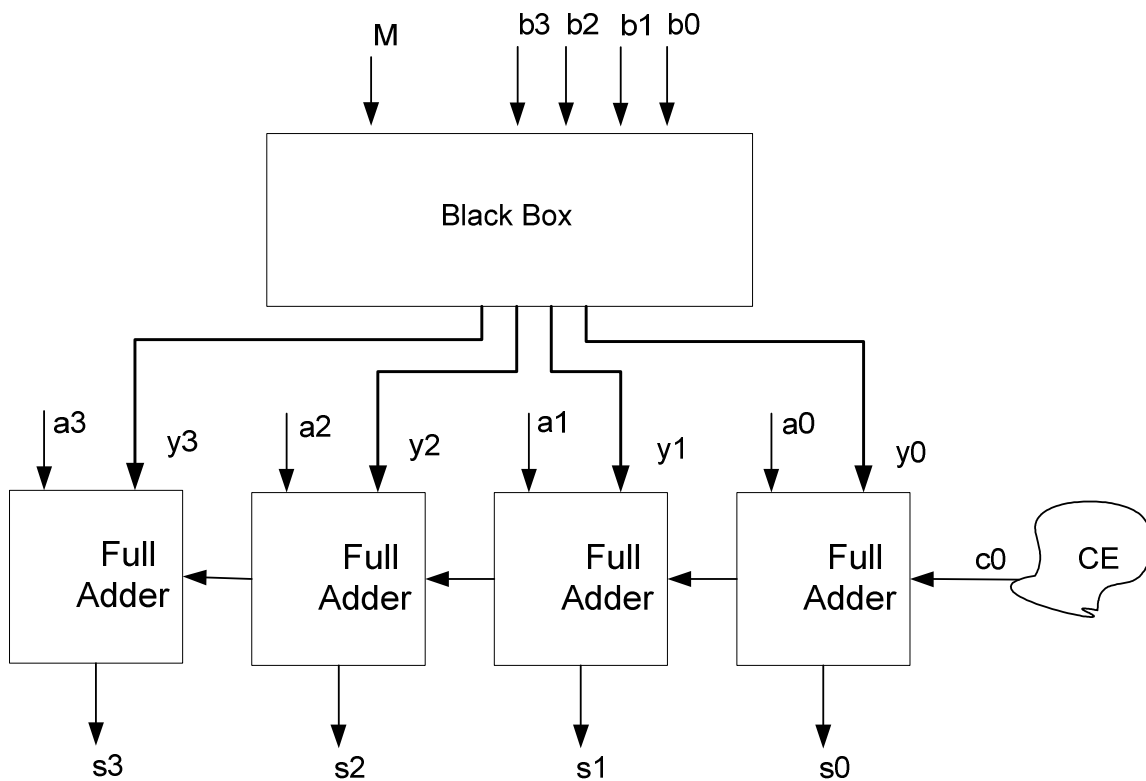

Student ID: _____

- a. Fill the following table for y_3 , y_2 , y_1 , y_0 and c_0 based on the inputs of the AU which are a_3 , a_2 , a_1 , a_0 , b_3 , b_2 , b_1 , b_0 , M_1 and M_0 . [10 points]

M1	M0	y3	y2	y1	y0	c0
0	0					
0	1					
1	0					
1	1					

Student ID: _____

- b.** Using the table that you reached in part (a), derive the logic equations for y_1 , y_0 and c_0 . **[5 points]**

Student ID: _____

Q2: [FSM Design] [15 points]

Design an FSM for a circuit which has a 2-bit input X and an output Y . The output Y becomes 1 if the cumulative sum of the numbers in sequence X multiple of 3. Otherwise Y is 0.

For example:

X: 00 → 11 → 01 → 10 → 00 → 01 ...
Y: 1 → 1 → 0 → 1 → 1 → 0 ...

Student ID: _____

<This page is intentionally left blank>

Student ID: _____

Q3: [Component based design] [15 points]

Using only one 3-bit binary counter and components as listed below, design a counter that generates the following sequence repeatedly:

(NOTE: The 3-bit counter starts counting from 0 to 7.)

25 → 22 → 19 → 16 → 13 → 10 → 7 → 4 → 25

- a) Shifter
- b) Adder
- c) Subtractor
- d) Comparator

Student ID: _____

<This page is intentionally left blank>

Student ID: _____

Q4: [Custom Design]

[10 points]

Design a circuit which executes the following code:

If $(A+B > 14)$

Then $S = C + D + 1$

Else

$S = C + D$

A, B, C and D are 4-bit binary numbers!

You can use the following components:

- Adder
- Comparator
- Subtractor
- Multiplexer
- Counter

HINT: There is a tricky solution to this problem which uses just adders. If you achieve designing this circuit using **only** 4-bit adders you can earn an **extra credit of 5 points**.

Student ID: _____

<This page is intentionally left blank>