

1. You are given the following network topology: (14pts.)

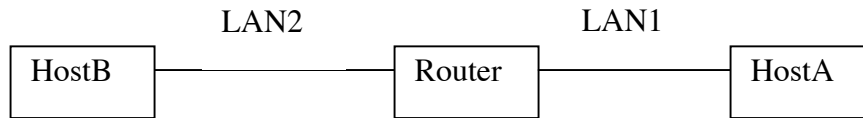

- Router is set as a default router for both HostA and HostB.
 - HostA and HostB's ARP tables are cleared, the router ARP tables are **not** cleared (i.e., removing the need of two transmissions to router – no packet dropping).
 - Then HostB pings HostA
- a. Below find a list of packets that may or may not be transmitted, on each LAN as indicated, when the HostB pings HostA. For each frame/packet, indicate if it was or was not transmitted on the indicated LAN (True or False).
 - b. For those that you determine were transmitted (i.e., TRUE), arrange in order of transmission, i.e., indicate the sequence of packet transmission events as they play out on the two LANs.
 - c. Fill in the fields of the various frames/packets transmitted, e.g., Ethernet source and destination addresses, IP source and destination addresses, etc. for the frames/packets that traverse the two LANs. (Use the following notation for your answer: HostA_eth0, or Router_eth1, HostA_IP, HostB_IP, etc., for broadcast use the hexadecimal notation). Assume the Router interface on LAN1 is eth0 and IP address is IP1 and on LAN2 it is eth1 and IP2

[Transmissions on LAN1]

ARP Request: sent? True or False

eth_src =
eth_dst =
sender_ip =
target ip =

ARP Reply: sent? True or False

eth_src =
eth_dst =
sender_ip =
target ip =

ICMP Echo Request: sent? True or False

eth_src =
eth_dest =
ip_src =
ip_dest =

ICMP Echo Reply: sent? True or False

eth_src =
eth_dest =
ip_src =
ip_dest =

[Transmissions on LAN2]

ARP Request: sent? True or False

eth_src =
eth_dst =
sender_ip =
target ip =

ARP Reply: sent? True or False

eth_src =
eth_dst =
sender_ip =
target ip =

ICMP Echo Request: sent? True or False

eth_src =
eth_dest =
ip_src =
ip_dest =

ICMP Echo Reply: sent? True or False

eth_src =
eth_dest =
ip_src =
ip_dest =

- ThetaCorp has been assigned four campus network addresses with prefix 24 208.201.4.0, 208.201.5.0, 208.201.6.0 and 208.201.7.0. You want to combine these addresses to create one logical flat network. Which subnet mask must you use? (-1pt. - +1pt.)

- 255.255.252.0
- 255.255.255.254
- 255.255.254.0
- 255.255.255.252

- Four Hosts are connected to one hub. (-2pts. - +2pts.)

- Host1 10.0.1.100/8
 Host2 10.0.1.142/16
 Host3 10.0.1.124/24
 Host4 10.0.1.130/28

Circle all the pairs that can ping successfully to each other.

- Host1 and Host2
- Host1 and Host3
- Host1 and Host4
- Host2 and Host3
- Host2 and Host4
- Host3 and Host4

- A datagram is sent from Host A on LAN1 to Host B on LAN2 via a bridge B as shown in the figure below. Assume that all ARP caches, routing tables and forwarding tables are up to date. Draw the Ethernet and IP headers of the packet as it flows from Host A over LAN1 via the bridge B and over LAN2 to Host2. Use Eth_HostA, IP_HostA, Eth_Bridge, IP_Bridge, etc. for your addressing scheme. (2pts.)

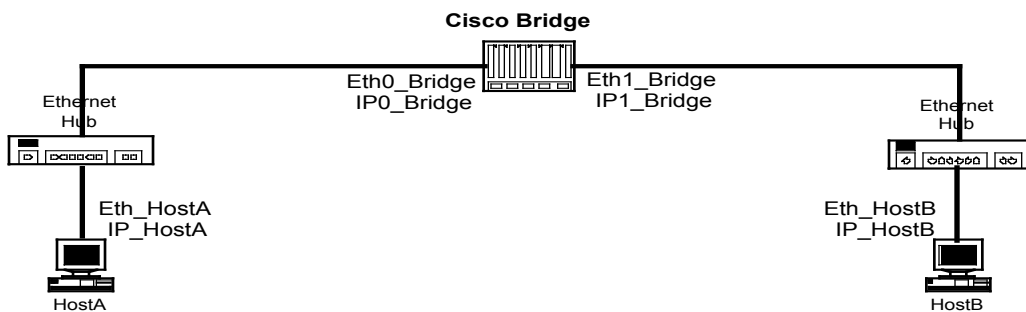

- Now assume that instead of a bridge we have a router R instead connecting the two LANs as shown below. Repeat problem 11 above with the same assumptions. (2pts.)

