Introduction to Machine Learning

Reading for today: R&N 18.1-18.4

Next lecture: R&N 18.6-18.12, 20.1-20.3.2

Outline

- The importance of a good representation
- Different types of learning problems
- Different types of learning algorithms
- Supervised learning
 - Decision trees
 - Naive Bayes
 - Perceptrons, Multi-layer Neural Networks
 - Boosting
- Unsupervised Learning
 - K-means
- Applications: learning to detect faces in images
- Reading for today's lecture: Chapter 18.1 to 18.4 (inclusive)

You will be expected to know

- Understand Attributes, Error function, Classification, Regression, Hypothesis (Predictor function)
- What is Supervised Learning?
- Decision Tree Algorithm
- Entropy
- Information Gain
- Tradeoff between train and test with model complexity
- Cross validation

Complete architectures for intelligence?

Search?

Solve the problem of what to do.

Learning?

Learn what to do.

Logic and inference?

Reason about what to do.

Encoded knowledge/"expert" systems?

Know what to do.

Modern view: It's complex & multi-faceted.

Automated Learning

- Why is it useful for our agent to be able to learn?
 - Learning is a key hallmark of intelligence
 - The ability of an agent to take in real data and feedback and improve performance over time
 - Check out USC Autonomous Flying Vehicle Project!
- Types of learning
 - Supervised learning
 - Learning a mapping from a set of inputs to a target variable
 - Classification: target variable is discrete (e.g., spam email)
 - Regression: target variable is real-valued (e.g., stock market)
 - Unsupervised learning
 - No target variable provided
 - Clustering: grouping data into K groups
 - Other types of learning
 - Reinforcement learning: e.g., game-playing agent
 - Learning to rank, e.g., document ranking in Web search
 - And many others....



The importance of a good representation

- **Properties of a good representation:**
- Reveals important features
- Hides irrelevant detail
- Exposes useful constraints
- Makes frequent operations easy-to-do
- Supports local inferences from local features
 - Called the “soda straw” principle or “locality” principle
 - Inference from features “through a soda straw”
- Rapidly or efficiently computable
 - It’s nice to be fast

Reveals important features / Hides irrelevant detail

- “You can’t learn what you can’t represent.” --- G. Sussman
- **In search:** *A man is traveling to market with a fox, a goose, and a bag of oats. He comes to a river. The only way across the river is a boat that can hold the man and exactly one of the fox, goose or bag of oats. The fox will eat the goose if left alone with it, and the goose will eat the oats if left alone with it.*
- **A good representation makes this problem easy:**

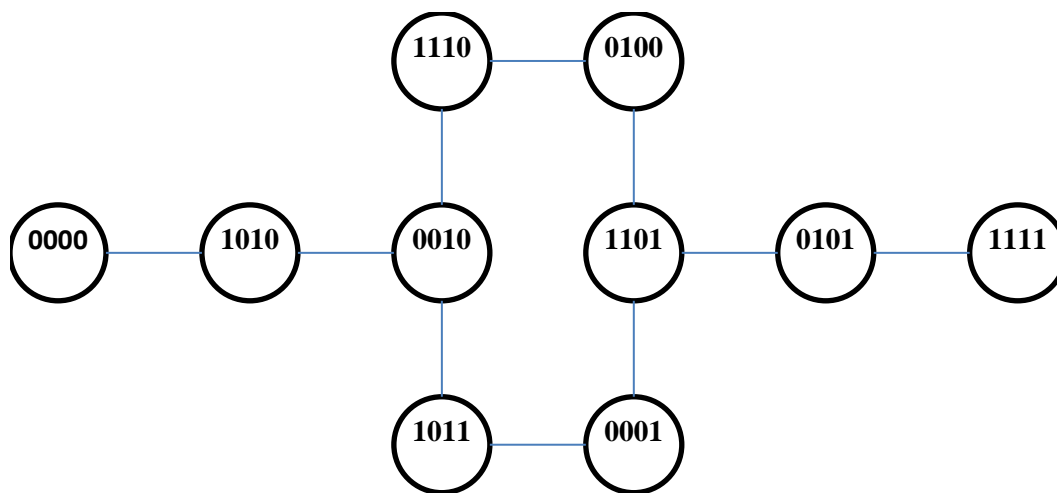

Simple illustrative learning problem

Problem:

decide whether to wait for a table at a restaurant, based on the following attributes:

1. Alternate: is there an alternative restaurant nearby?
2. Bar: is there a comfortable bar area to wait in?
3. Fri/Sat: is today Friday or Saturday?
4. Hungry: are we hungry?
5. Patrons: number of people in the restaurant (None, Some, Full)
6. Price: price range (\$, \$\$, \$\$\$)
7. Raining: is it raining outside?
8. Reservation: have we made a reservation?
9. Type: kind of restaurant (French, Italian, Thai, Burger)
10. WaitEstimate: estimated waiting time (0-10, 10-30, 30-60, >60)

Training Data for Supervised Learning

Example	Attributes										Target <i>Wait</i>
	<i>Alt</i>	<i>Bar</i>	<i>Fri</i>	<i>Hun</i>	<i>Pat</i>	<i>Price</i>	<i>Rain</i>	<i>Res</i>	<i>Type</i>	<i>Est</i>	
X_1	T	F	F	T	Some	\$\$\$	F	T	French	0–10	T
X_2	T	F	F	T	Full	\$	F	F	Thai	30–60	F
X_3	F	T	F	F	Some	\$	F	F	Burger	0–10	T
X_4	T	F	T	T	Full	\$	F	F	Thai	10–30	T
X_5	T	F	T	F	Full	\$\$\$	F	T	French	>60	F
X_6	F	T	F	T	Some	\$\$	T	T	Italian	0–10	T
X_7	F	T	F	F	None	\$	T	F	Burger	0–10	F
X_8	F	F	F	T	Some	\$\$	T	T	Thai	0–10	T
X_9	F	T	T	F	Full	\$	T	F	Burger	>60	F
X_{10}	T	T	T	T	Full	\$\$\$	F	T	Italian	10–30	F
X_{11}	F	F	F	F	None	\$	F	F	Thai	0–10	F
X_{12}	T	T	T	T	Full	\$	F	F	Burger	30–60	T

Terminology

- Attributes
 - Also known as features, variables, independent variables, covariates
- Target Variable
 - Also known as goal predicate, dependent variable, ...
- Classification
 - Also known as discrimination, supervised classification, ...
- Error function
 - Objective function, loss function, ...

Inductive learning

- Let x represent the input vector of attributes
- Let $f(x)$ represent the value of the target variable for x
 - The implicit mapping from x to $f(x)$ is unknown to us
 - We just have training data pairs, $D = \{x, f(x)\}$ available
- We want to learn a mapping from x to f , i.e.,
 $h(x; \theta)$ is “close” to $f(x)$ for all training data points x

 θ are the parameters of our predictor $h(..)$
- Examples:
 - $h(x; \theta) = \text{sign}(w_1x_1 + w_2x_2 + w_3)$
 - $h_k(x) = (x_1 \text{ OR } x_2) \text{ AND } (x_3 \text{ OR NOT}(x_4))$

Empirical Error Functions

- Empirical error function:

$$E(h) = \sum_x \text{distance}[h(x; \theta) , f]$$

e.g., distance = squared error if h and f are real-valued (regression)
distance = delta-function if h and f are categorical (classification)

Sum is over all training pairs in the training data D

In learning, we get to choose

1. what class of functions $h(\cdot)$ that we want to learn
 - potentially a huge space! (“hypothesis space”)
2. what error function/distance to use
 - should be chosen to reflect real “loss” in problem
 - but often chosen for mathematical/algorithmic convenience

Inductive Learning as Optimization or Search

- Empirical error function:

$$E(h) = \sum_x \text{distance}[h(x; \theta), f]$$

- Empirical learning = finding $h(x)$, or $h(x; \theta)$ that minimizes $E(h)$
 - In simple problems there may be a closed form solution
 - E.g., “normal equations” when h is a linear function of x , E = squared error
 - If $E(h)$ is differentiable as a function of q , then we have a continuous optimization problem and can use gradient descent, etc
 - E.g., multi-layer neural networks
 - If $E(h)$ is non-differentiable (e.g., classification), then we typically have a systematic search problem through the space of functions h
 - E.g., decision tree classifiers
- Once we decide on what the functional form of h is, and what the error function E is, then machine learning typically reduces to a large search or optimization problem
- Additional aspect: we really want to learn an $h(\dots)$ that will generalize well to new data, not just memorize training data – will return to this later

Our training data example (again)

Example	Attributes										Target
	<i>Alt</i>	<i>Bar</i>	<i>Fri</i>	<i>Hun</i>	<i>Pat</i>	<i>Price</i>	<i>Rain</i>	<i>Res</i>	<i>Type</i>	<i>Est</i>	<i>Wait</i>
X_1	T	F	F	T	Some	\$\$\$	F	T	French	0–10	T
X_2	T	F	F	T	Full	\$	F	F	Thai	30–60	F
X_3	F	T	F	F	Some	\$	F	F	Burger	0–10	T
X_4	T	F	T	T	Full	\$	F	F	Thai	10–30	T
X_5	T	F	T	F	Full	\$\$\$	F	T	French	>60	F
X_6	F	T	F	T	Some	\$\$	T	T	Italian	0–10	T
X_7	F	T	F	F	None	\$	T	F	Burger	0–10	F
X_8	F	F	F	T	Some	\$\$	T	T	Thai	0–10	T
X_9	F	T	T	F	Full	\$	T	F	Burger	>60	F
X_{10}	T	T	T	T	Full	\$\$\$	F	T	Italian	10–30	F
X_{11}	F	F	F	F	None	\$	F	F	Thai	0–10	F
X_{12}	T	T	T	T	Full	\$	F	F	Burger	30–60	T

- If all attributes were binary, $h(\cdot)$ could be any arbitrary Boolean function
- Natural error function $E(h)$ to use is classification error, i.e., how many incorrect predictions does a hypothesis h make
- Note an implicit assumption:
 - For any set of attribute values there is a unique target value
 - This in effect assumes a “no-noise” mapping from inputs to targets
 - This is often not true in practice (e.g., in medicine). Will return to this later

Learning Boolean Functions

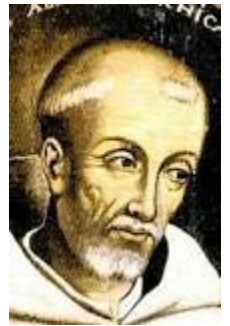

William of
Ockham
c. 1288-1347

- Given examples of the function, can we learn the function?
- How many Boolean functions can be defined on d attributes?
 - Boolean function = Truth table + column for target function (binary)
 - Truth table has 2^d rows
 - So there are 2 to the power of 2^d different Boolean functions we can define (!)
 - This is the size of our hypothesis space
 - E.g., $d = 6$, there are 18.4×10^{18} possible Boolean functions
- Observations:
 - Huge hypothesis spaces \rightarrow directly searching over all functions is impossible
 - Given a small data (n pairs) our learning problem may be underconstrained
 - Ockham's razor: if multiple candidate functions all explain the data equally well, pick the simplest explanation (least complex function)
 - Constrain our search to classes of Boolean functions, e.g.,
 - decision trees
 - Weighted linear sums of inputs (e.g., perceptrons)

Decision Tree Learning

Constrain $h(\cdot)$ to be a decision tree

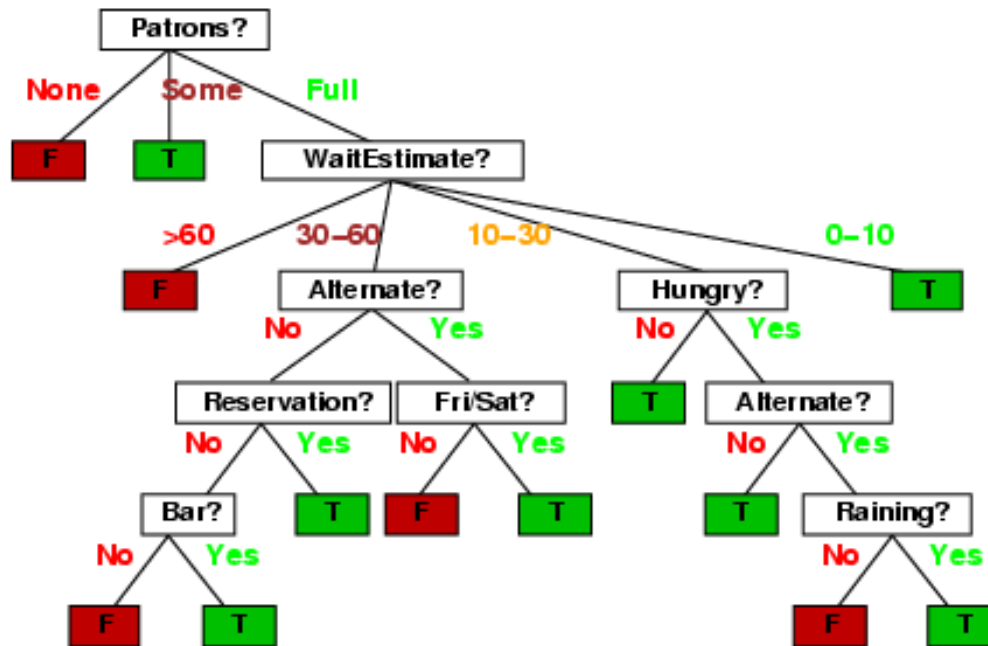

Decision Tree Representations

Decision trees are fully expressive

can represent any Boolean function

Every path in the tree could represent 1 row in the truth table

Yields an exponentially large tree

Truth table is of size 2^d , where d is the number of attributes

A	B	A xor B
F	F	F
F	T	T
T	F	T
T	T	F

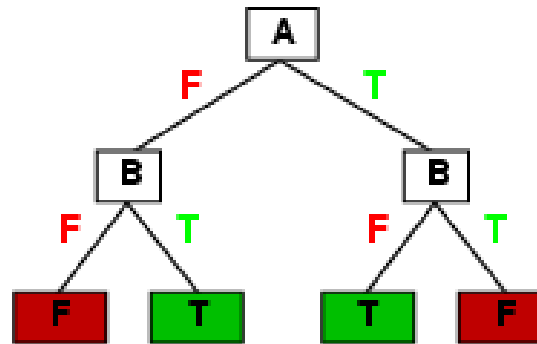

Decision Tree Representations

- Trees can be very inefficient for certain types of functions
 - Parity function: 1 only if an even number of 1's in the input vector
 - Trees are very inefficient at representing such functions
 - Majority function: 1 if more than $\frac{1}{2}$ the inputs are 1's
 - Also inefficient
 - Simple DNF formulae can be easily represented
 - E.g., $f = (A \text{ AND } B) \text{ OR } (\text{NOT}(A) \text{ AND } D)$
 - DNF = disjunction of conjunctions
- Decision trees are in effect DNF representations
 - often used in practice since they often result in compact approximate representations for complex functions
 - E.g., consider a truth table where most of the variables are irrelevant to the function

Decision Tree Learning

- Find the smallest decision tree consistent with the n examples
 - Unfortunately this is provably intractable to do optimally
- Greedy heuristic search used in practice:
 - Select root node that is “best” in some sense
 - Partition data into 2 subsets, depending on root attribute value
 - Recursively grow subtrees
 - Different termination criteria
 - For noiseless data, if all examples at a node have the same label then declare it a leaf and backup
 - For noisy data it might not be possible to find a “pure” leaf using the given attributes
 - we’ll return to this later – but a simple approach is to have a depth-bound on the tree (or go to max depth) and use majority vote
- We have talked about binary variables up until now, but we can trivially extend to multi-valued variables

Pseudocode for Decision tree learning

```
function DTL(examples, attributes, default) returns a decision tree
  if examples is empty then return default
  else if all examples have the same classification then return the classification
  else if attributes is empty then return MODE(examples)
  else
    best ← CHOOSE-ATTRIBUTE(attributes, examples)
    tree ← a new decision tree with root test best
    for each value  $v_i$  of best do
       $examples_i$  ← {elements of examples with best =  $v_i$ }
      subtree ← DTL( $examples_i$ , attributes – best, MODE(examples))
      add a branch to tree with label  $v_i$  and subtree subtree
  return tree
```

Choosing an attribute

- Idea: a good attribute splits the examples into subsets that are (ideally) "all positive" or "all negative"

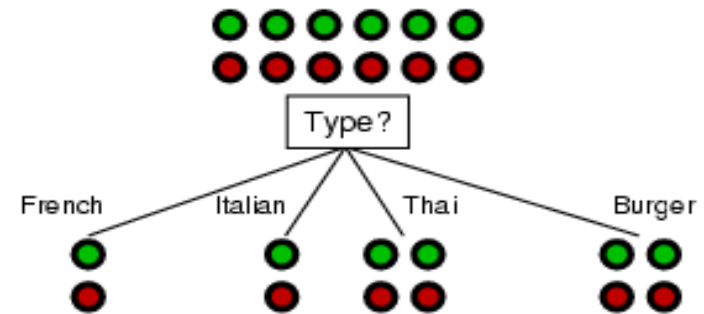
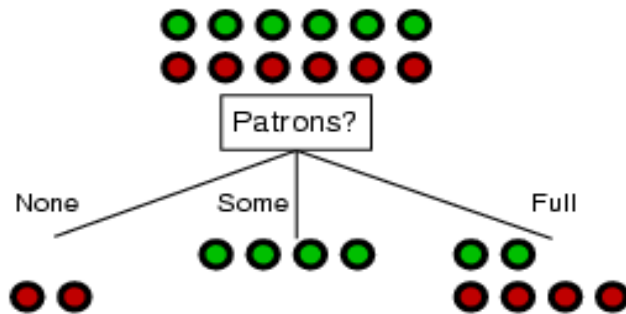

- Patrons?* is a better choice
 - How can we quantify this?
 - One approach would be to use the classification error E directly (greedily)
 - Empirically it is found that this works poorly
 - Much better is to use information gain (next slides)

Entropy

$H(\underline{p})$ = entropy of distribution $\underline{p} = \{p_i\}$
(called "information" in text)

$$= E [p_i \log (1/p_i)] = - p \log p - (1-p) \log (1-p)$$

Entropy is the expected amount of information we gain, given a probability distribution – its our average uncertainty

In general, $H(p)$ is maximized when all p_i are equal and minimized (=0) when one of the p_i 's is 1 and all others zero.

Entropy with only 2 outcomes

Consider 2 class problem: p = probability of class 1, $1 - p$ = probability of class 2

In binary case, $H(p) = -p \log p - (1-p) \log (1-p)$

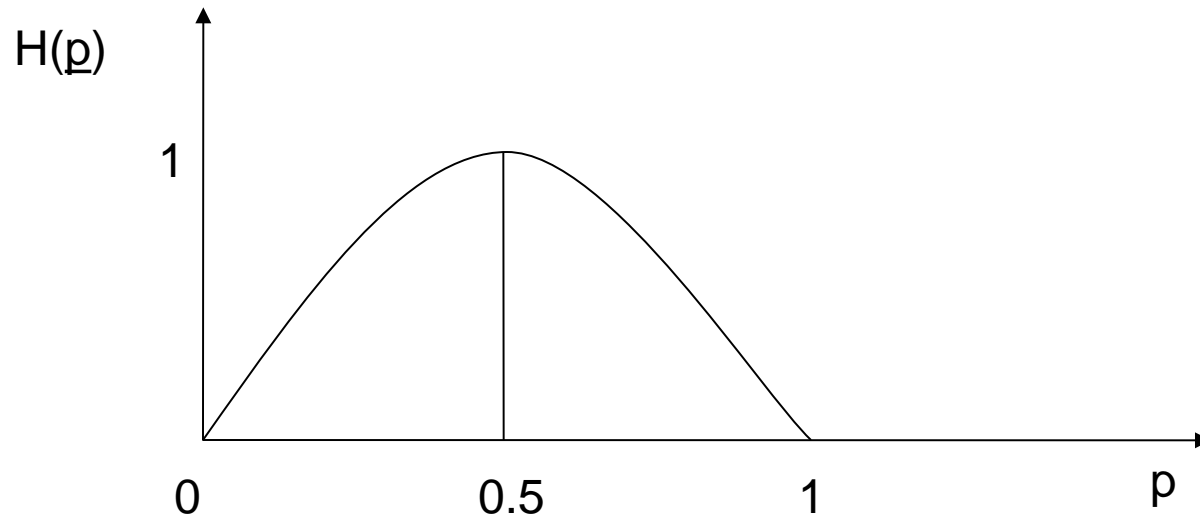

Information Gain

- $H(p)$ = entropy of class distribution at a particular node
- $H(p | A)$ = conditional entropy = average entropy of conditional class distribution, after we have partitioned the data according to the values in A
- $\text{Gain}(A) = H(p) - H(p | A)$
- Simple rule in decision tree learning
 - At each internal node, split on the node with the largest information gain (or equivalently, with smallest $H(p|A)$)
- Note that by definition, conditional entropy can't be greater than the entropy

Root Node Example

For the training set, 6 positives, 6 negatives, $H(6/12, 6/12) = 1$ bit

positive (p)

negative (1-p)

$$\gg H(6/12, 6/12) = -(6/12) \cdot \log_2(6/12) - (6/12) \cdot \log_2(6/12)$$

Consider the attributes *Patrons* and *Type*:

$$I(\mathcal{E} | a) = 1 - \left[\frac{2}{12} H\left(\frac{0}{2}, 1\right) + \frac{4}{12} H\left(\frac{1}{2}, 0\right) + \frac{6}{12} H\left(\frac{2}{6}, \frac{4}{6}\right) \right] = 0.15 \text{ bits}$$

$$I(\mathcal{E} | G) = 1 - \left[\frac{2}{12} H\left(\frac{1}{2}, \frac{1}{2}\right) + \frac{2}{12} H\left(\frac{1}{2}, \frac{1}{2}\right) + \frac{4}{12} H\left(\frac{2}{4}, \frac{2}{4}\right) + \frac{4}{12} H\left(\frac{2}{4}, \frac{2}{4}\right) \right] = 0 \text{ bits}$$

Patrons has the highest IG of all attributes and so is chosen by the learning algorithm as the root

Information gain is then repeatedly applied at internal nodes until all leaves contain only examples from one class or the other

Choosing an attribute

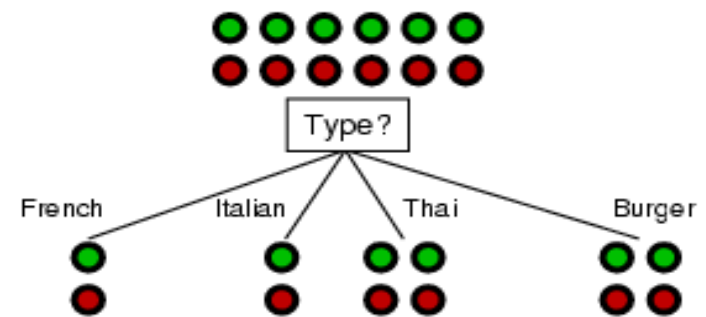
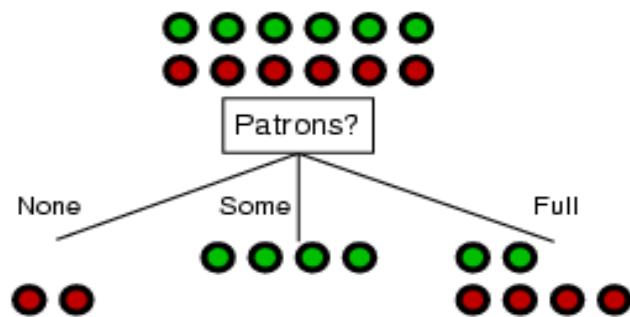

Decision Tree Learned

- Decision tree learned from the 12 examples:

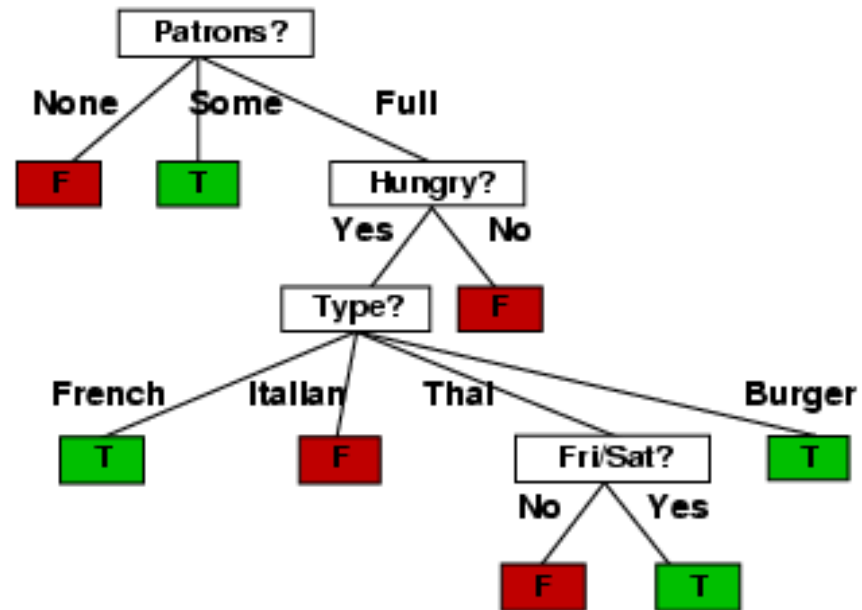

True Tree (left) versus Learned Tree (right)

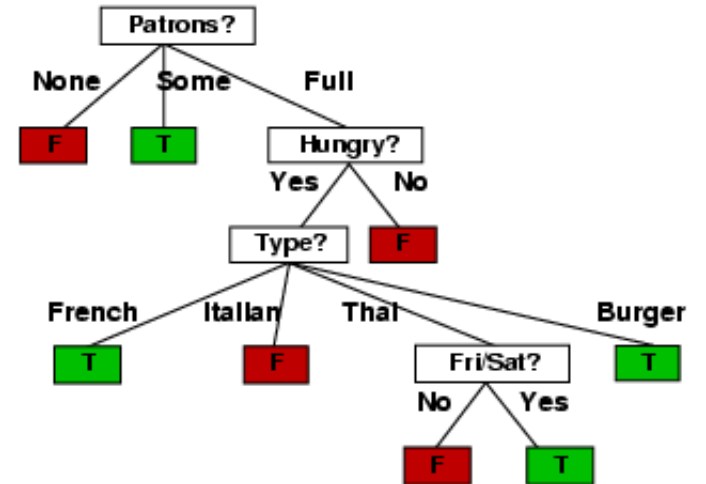
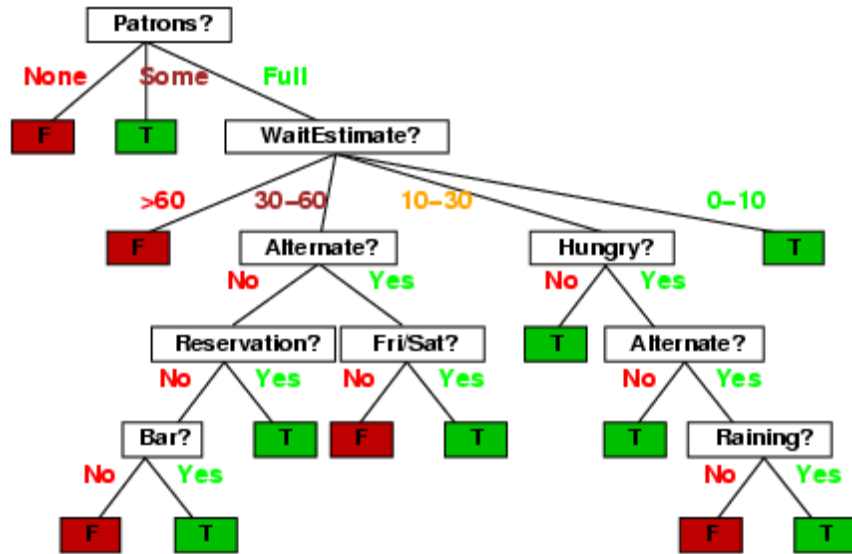

Assessing Performance

Training data performance is typically optimistic
e.g., error rate on training data

Reasons?

- classifier may not have enough data to fully learn the concept (but on training data we don't know this)
- for noisy data, the classifier may overfit the training data

In practice we want to assess performance "out of sample"
how well will the classifier do on new unseen data? This is the
true test of what we have learned (just like a classroom)

With large data sets we can partition our data into 2 subsets, train and test

- build a model on the training data
- assess performance on the test data

Example of Test Performance

Restaurant problem

- simulate 100 data sets of different sizes
- train on this data, and assess performance on an independent test set
- learning curve = plotting accuracy as a function of training set size
- typical “diminishing returns” effect (some nice theory to explain this)

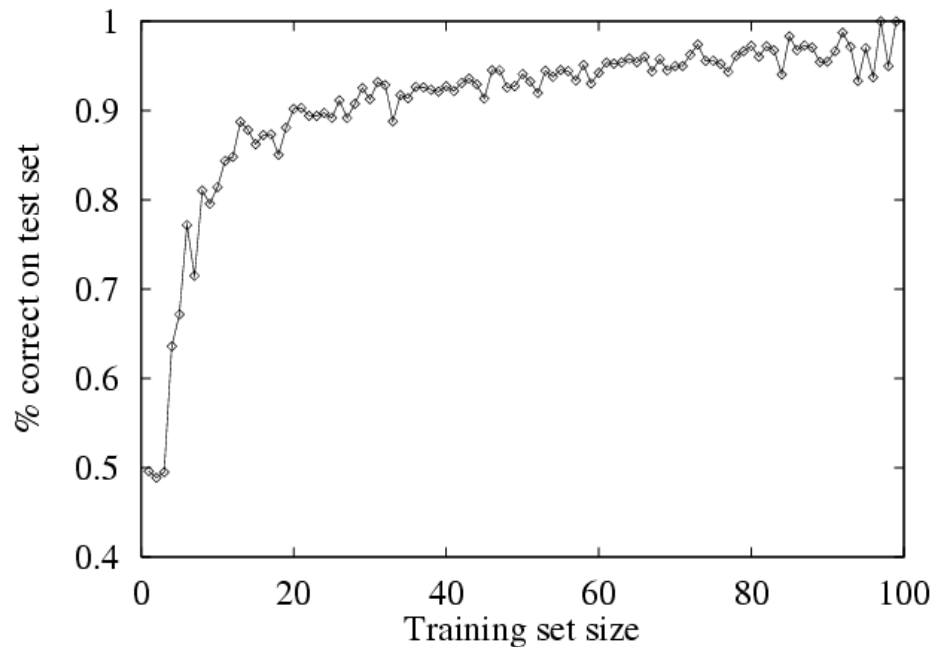

Overfitting and Underfitting

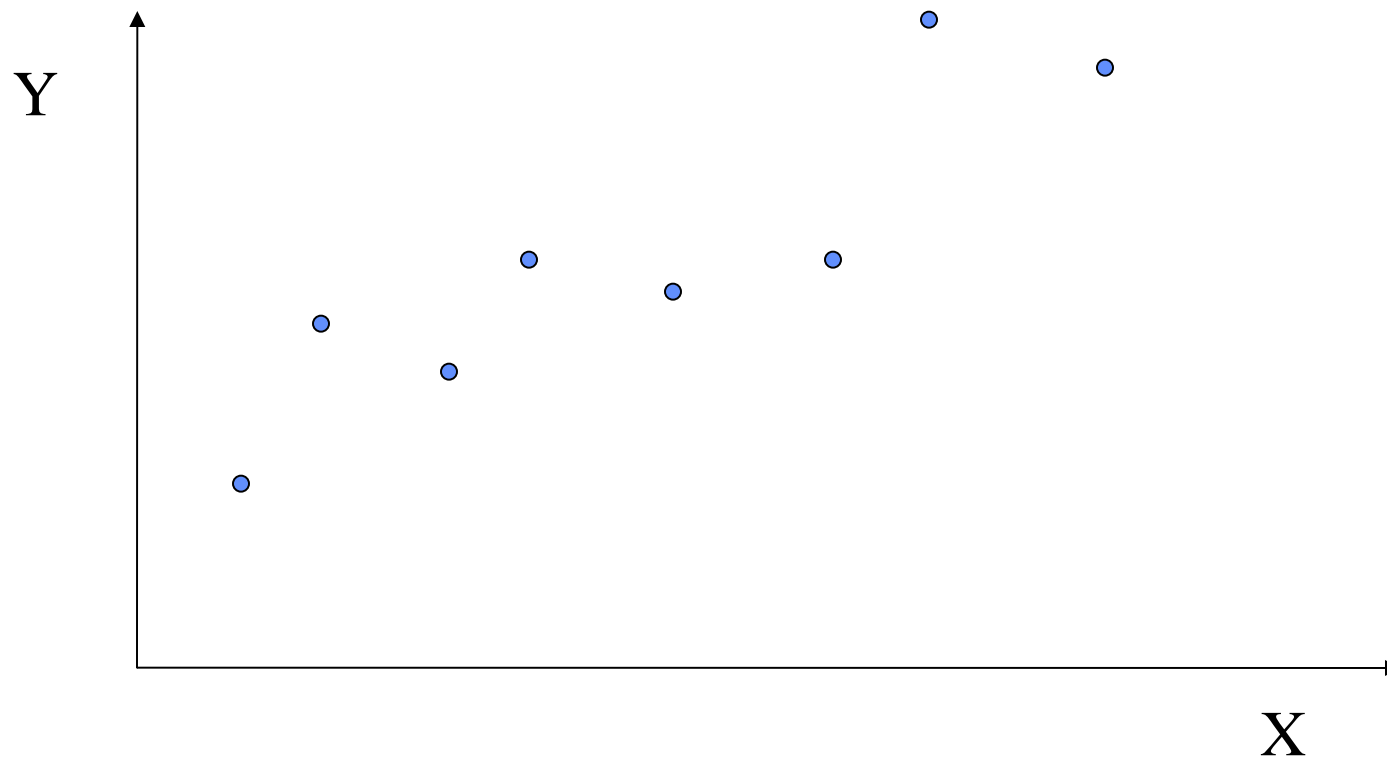

A Complex Model

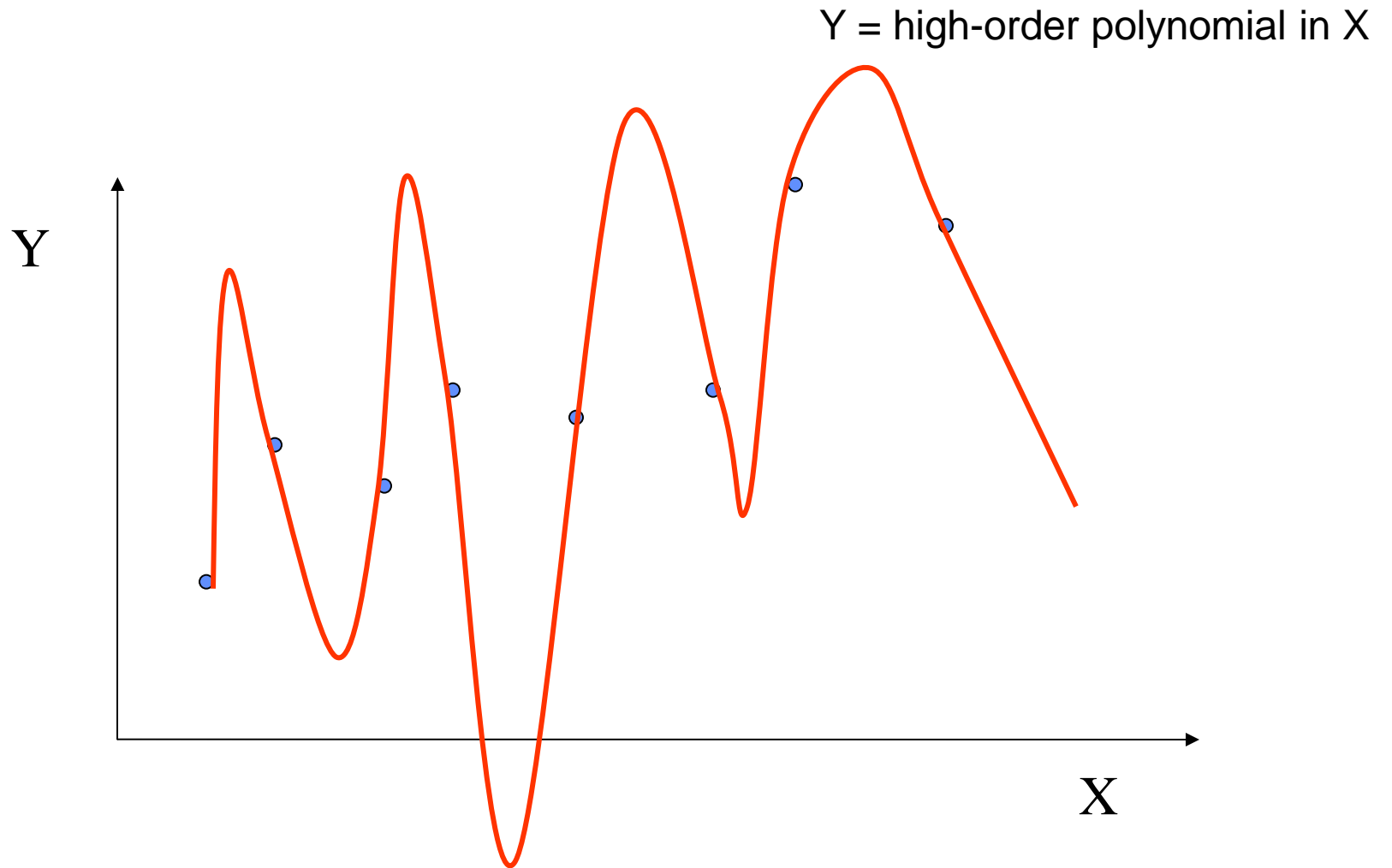

A Much Simpler Model

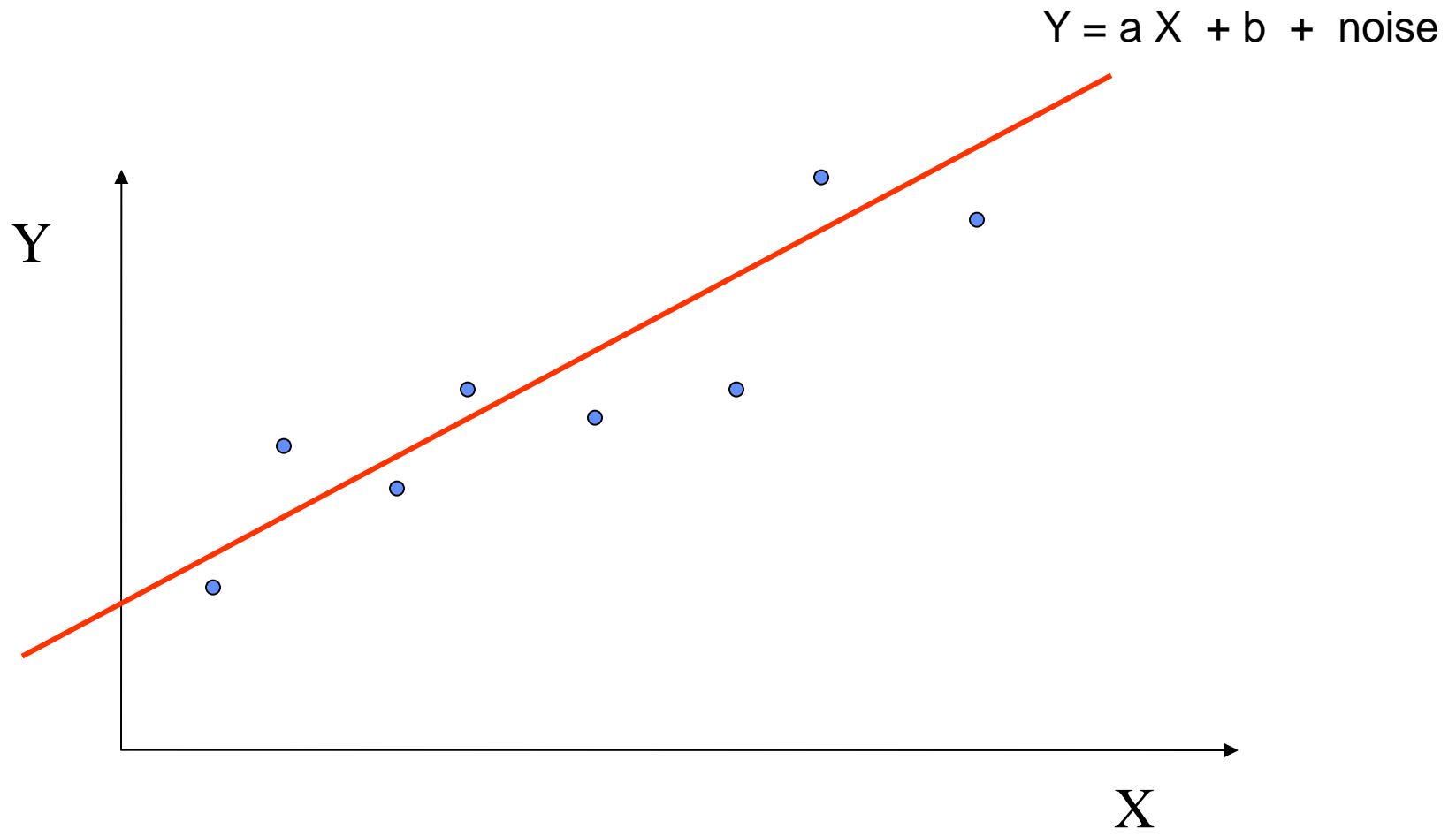

Example 2

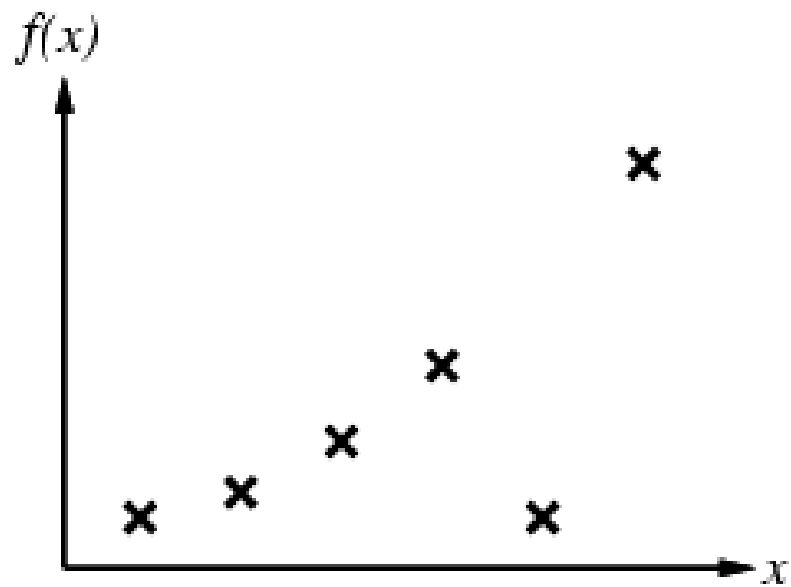

Example 2

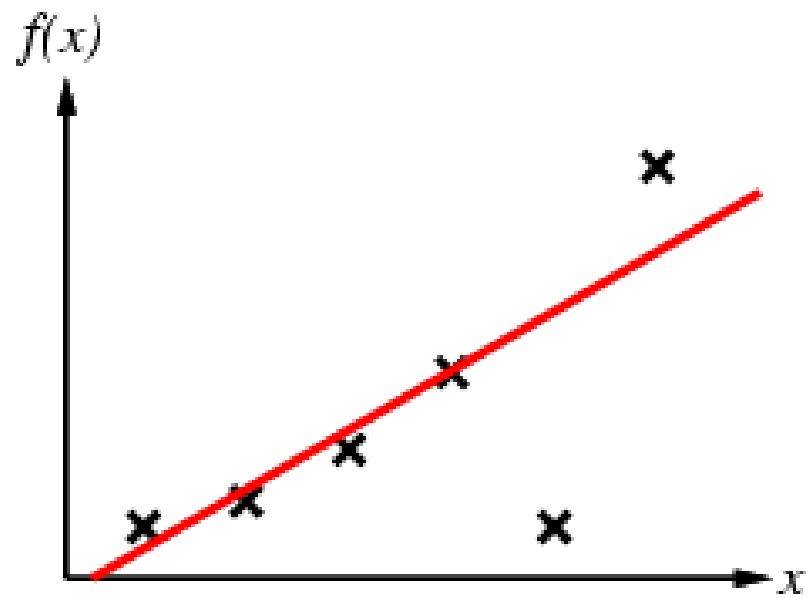

Example 2

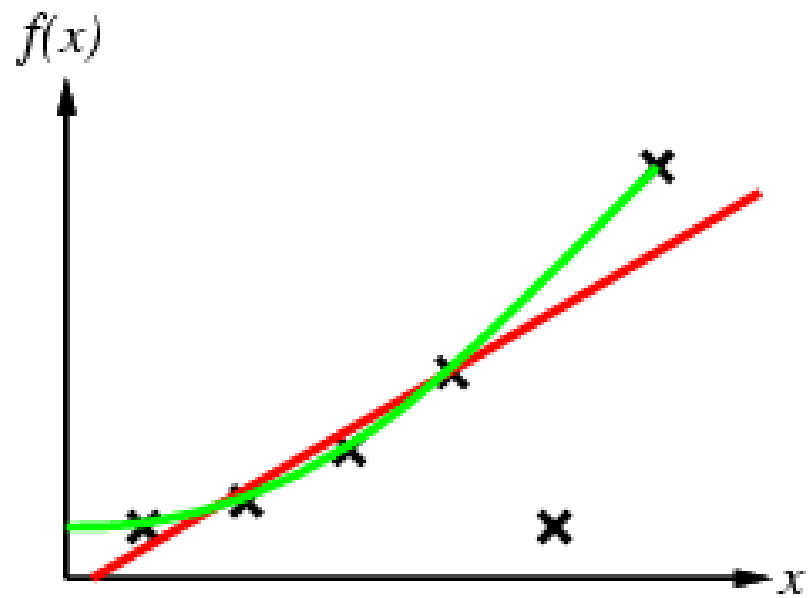

Example 2

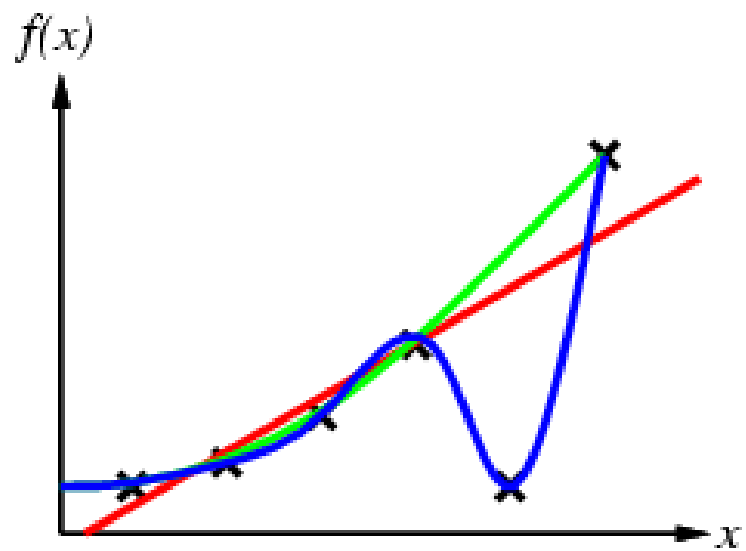

Example 2

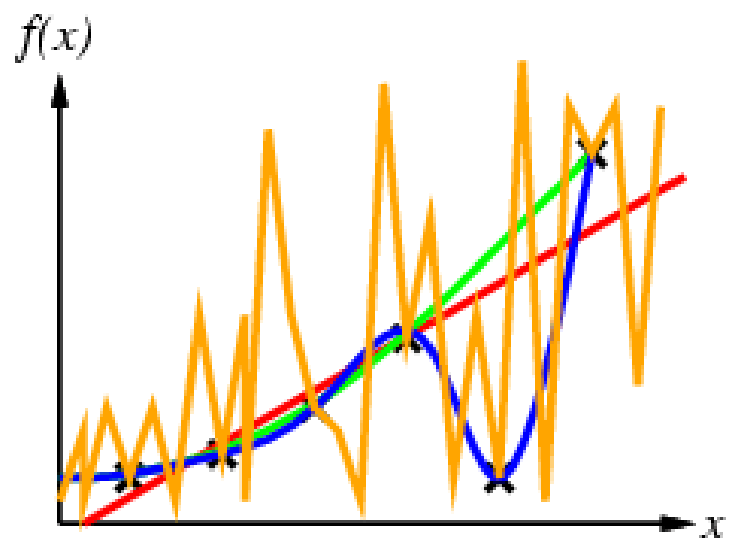

How Overfitting affects Prediction

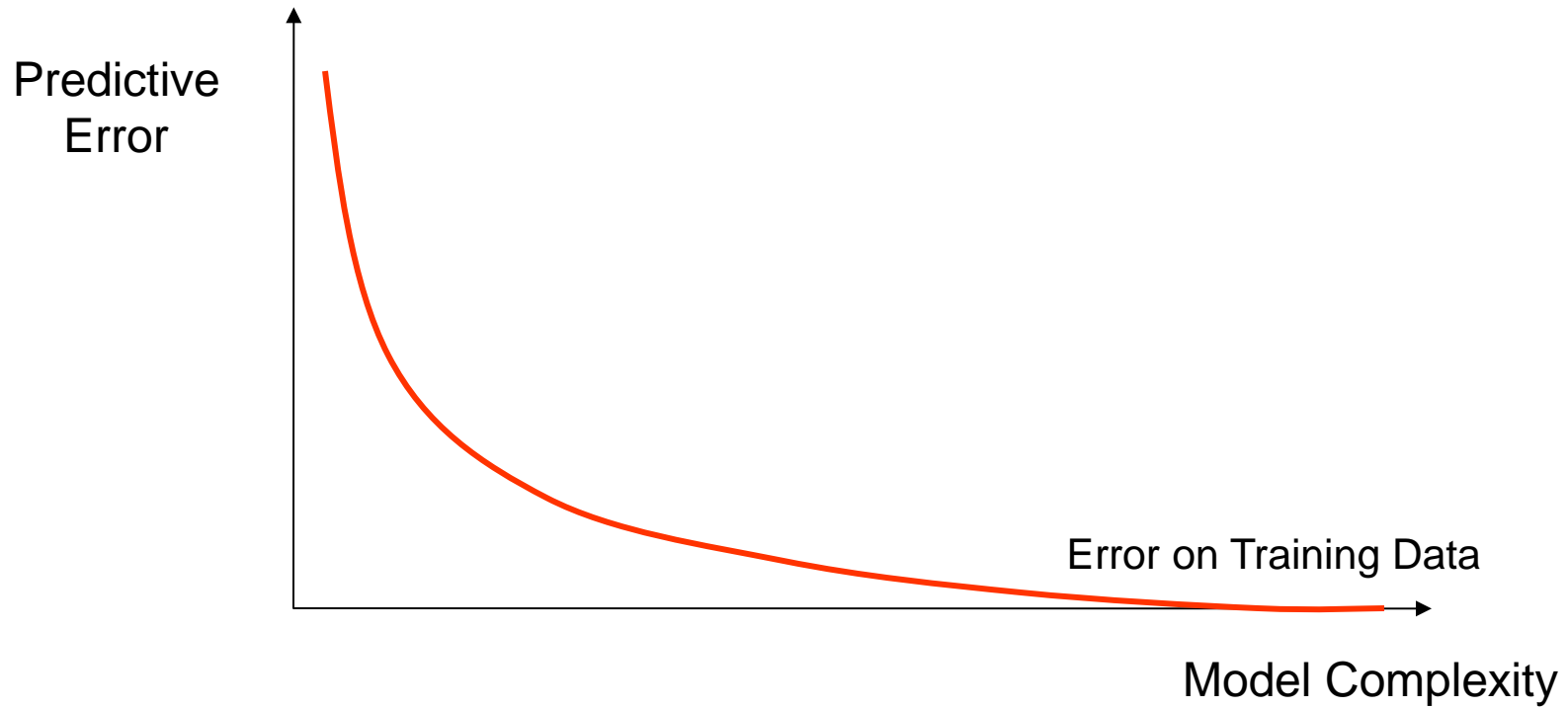

How Overfitting affects Prediction

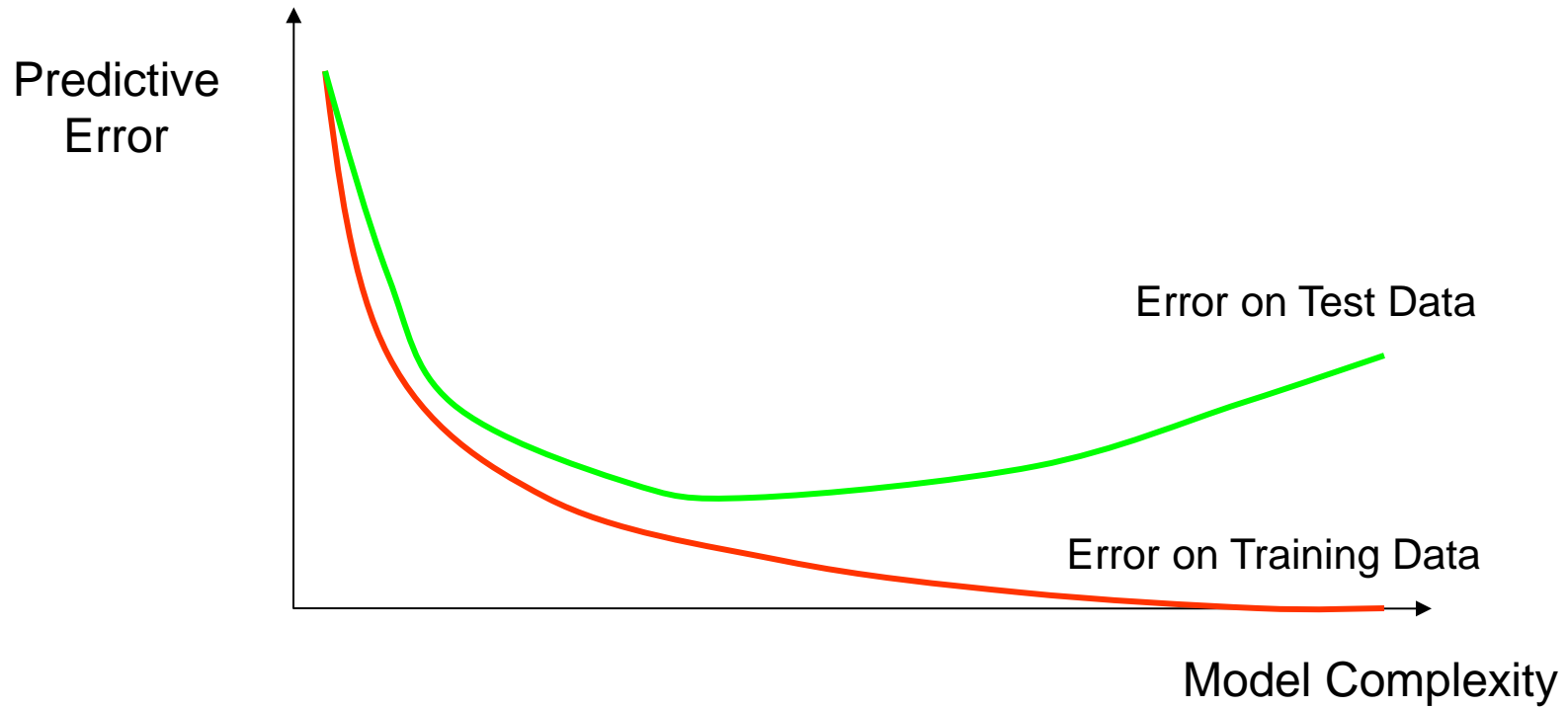

How Overfitting affects Prediction

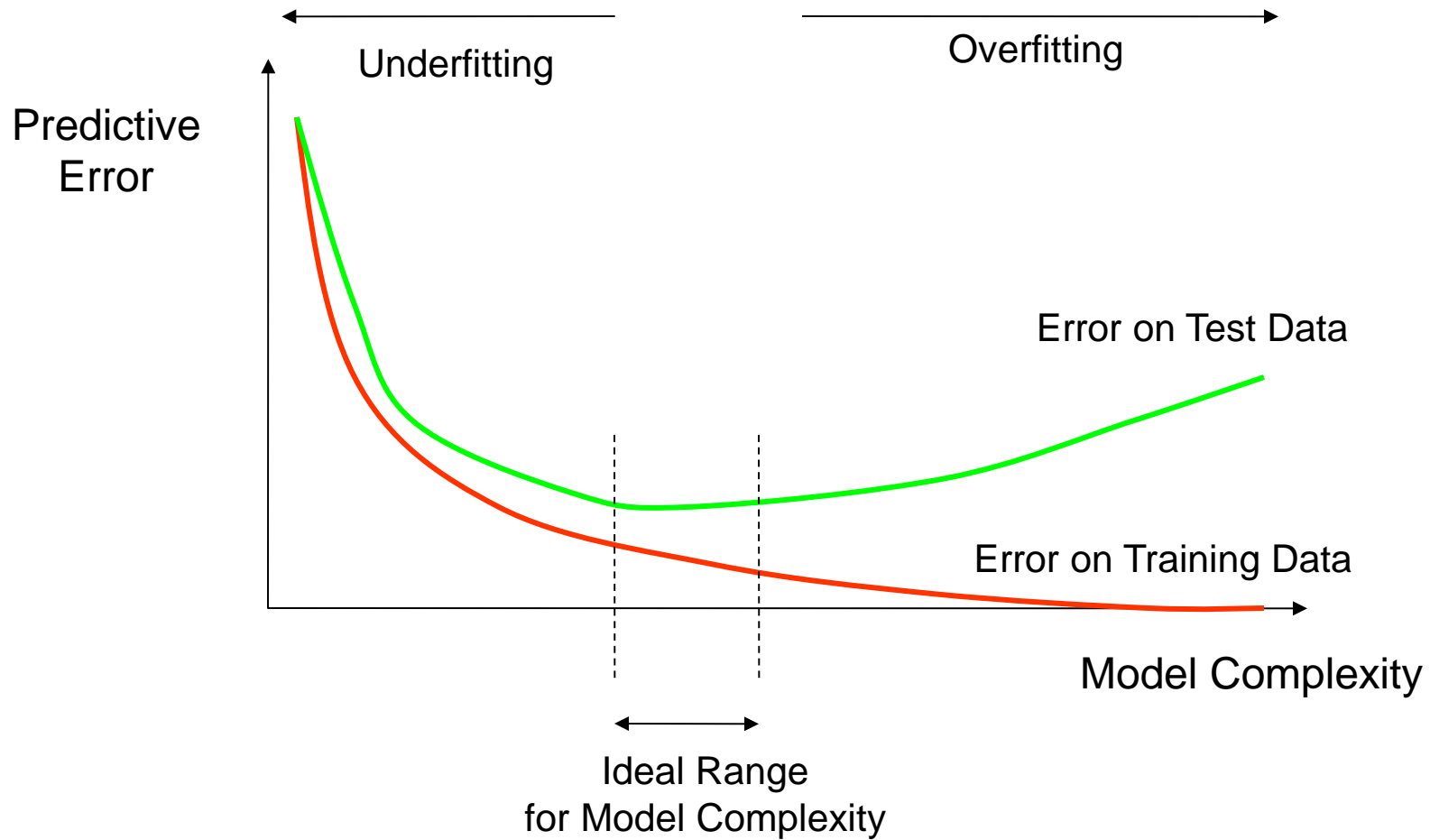

Training and Validation Data

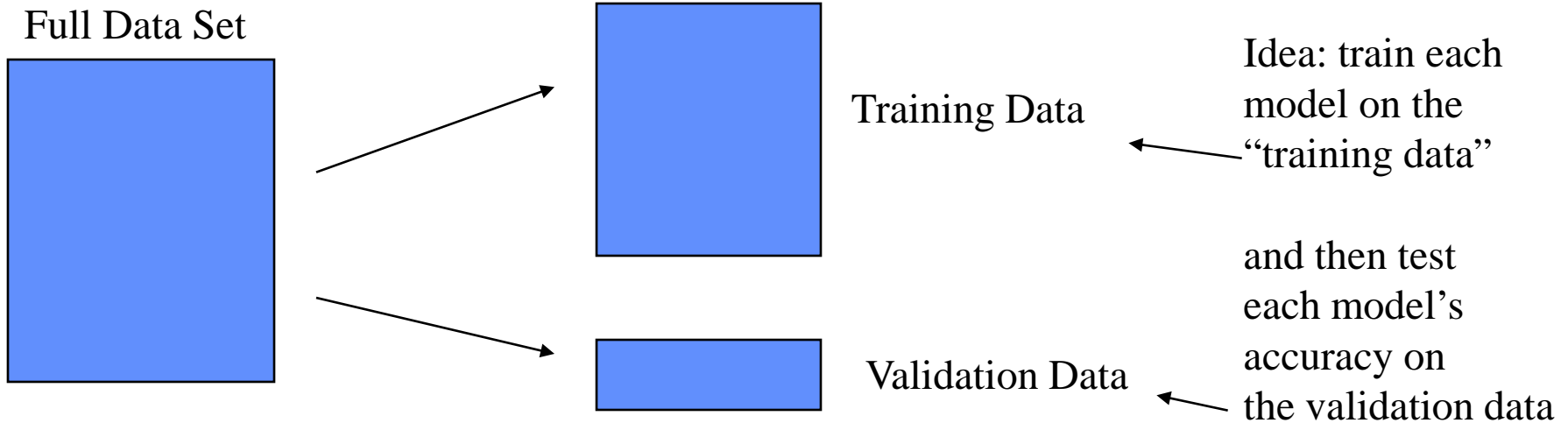

The k-fold Cross-Validation Method

- Why just choose one particular 90/10 “split” of the data?
 - In principle we could do this multiple times
- “k-fold Cross-Validation” (e.g., k=10)
 - randomly partition our full data set into k disjoint subsets (each roughly of size n/k , n = total number of training data points)
 - for $i = 1:10$ (here $k = 10$)
 - train on 90% of data,
 - $\text{Acc}(i)$ = accuracy on other 10%
 - end
 - Cross-Validation-Accuracy = $1/k \sum_i \text{Acc}(i)$
 - choose the method with the highest cross-validation accuracy
 - common values for k are 5 and 10
 - Can also do “leave-one-out” where $k = n$

Disjoint Validation Data Sets

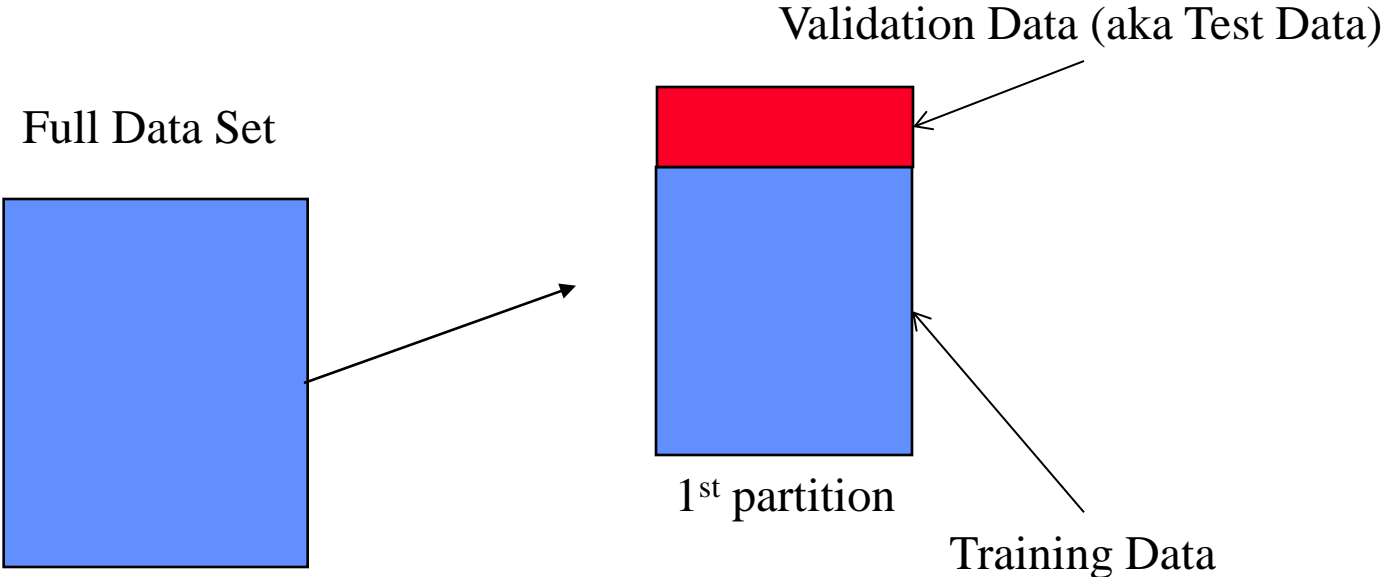

Disjoint Validation Data Sets

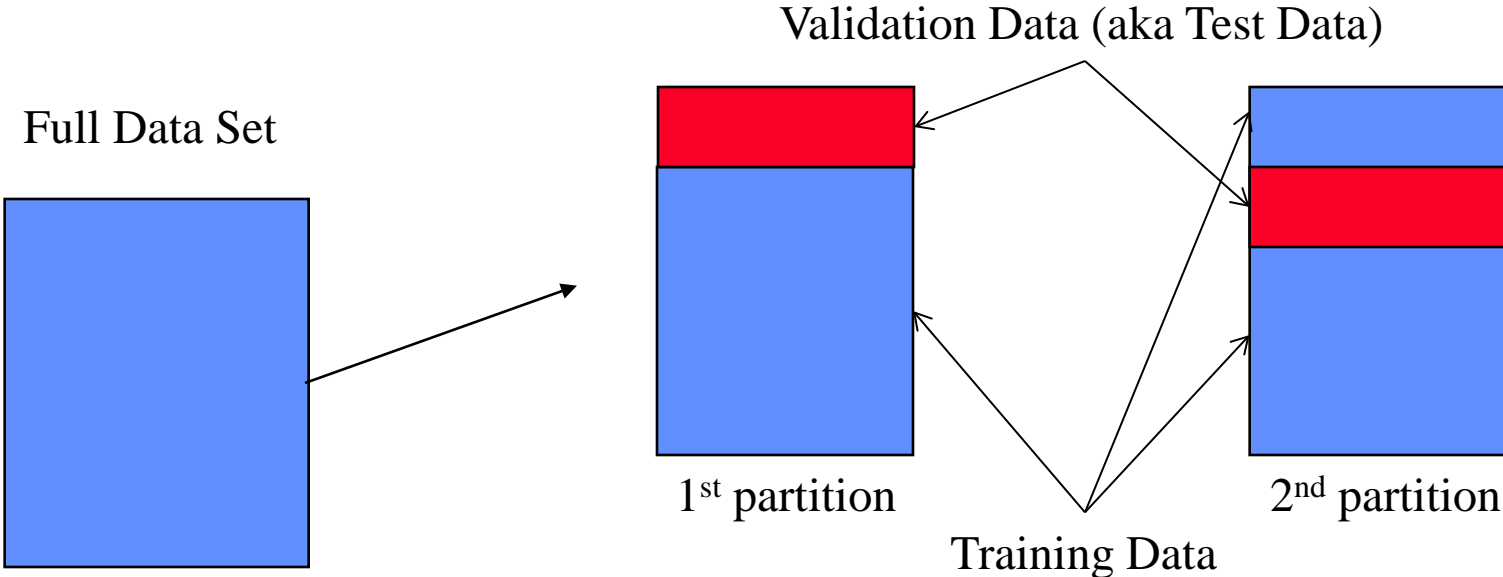

Disjoint Validation Data Sets

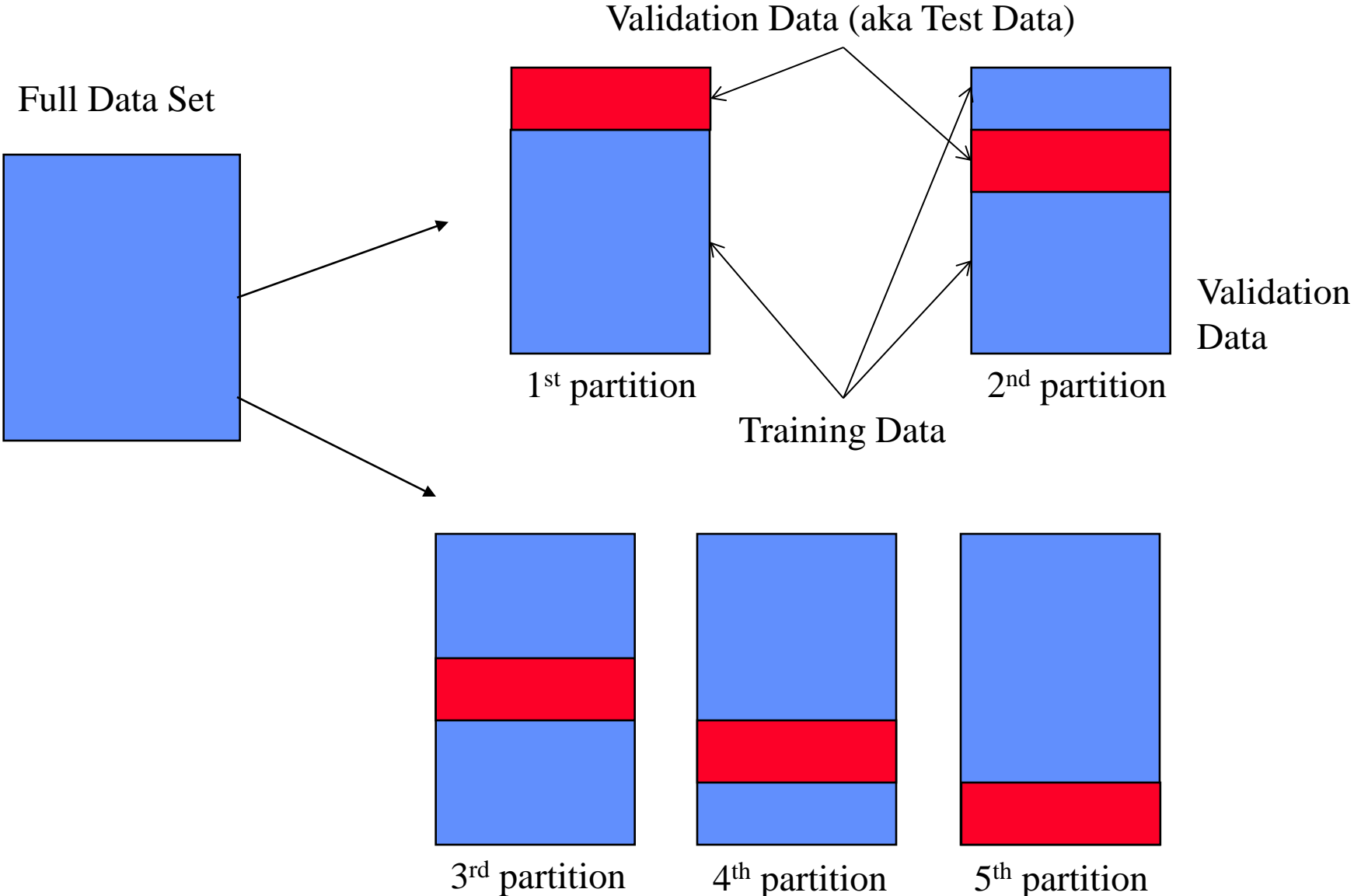

More on Cross-Validation

- Notes
 - cross-validation generates an approximate estimate of how well the learned model will do on “unseen” data
 - by averaging over different partitions it is more robust than just a single train/validate partition of the data
 - “k-fold” cross-validation is a generalization
 - partition data into disjoint validation subsets of size n/k
 - train, validate, and average over the k partitions
 - e.g., $k=10$ is commonly used
 - k-fold cross-validation is approximately k times computationally more expensive than just fitting a model to all of the data

Summary

- Inductive learning
 - Error function, class of hypothesis/models $\{h\}$
 - Want to minimize E on our training data
 - Example: decision tree learning
- Generalization
 - Training data error is over-optimistic
 - We want to see performance on test data
 - Cross-validation is a useful practical approach
- Learning to recognize faces
 - Viola-Jones algorithm: state-of-the-art face detector, entirely learned from data, using boosting+decision-stumps