

Introduction to Machine Learning

CS171, Summer 1 Quarter, 2019

Introduction to Artificial Intelligence

TA Edwin Solares

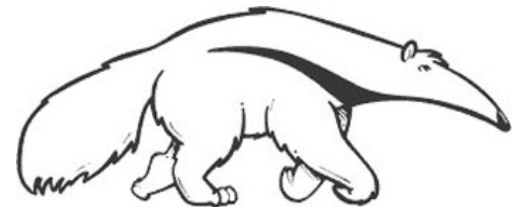

p53 and Human Cancers

Thanks to
Richard Lathrop

- p53 is a central tumor suppressor protein
“The guardian of the genome”
- Cancer Mutants:
About 50% of all human cancers have p53 mutations.
- Rescue Mutants:
Several second-site mutations restore functionality to some p53 cancer mutants *in vivo*.

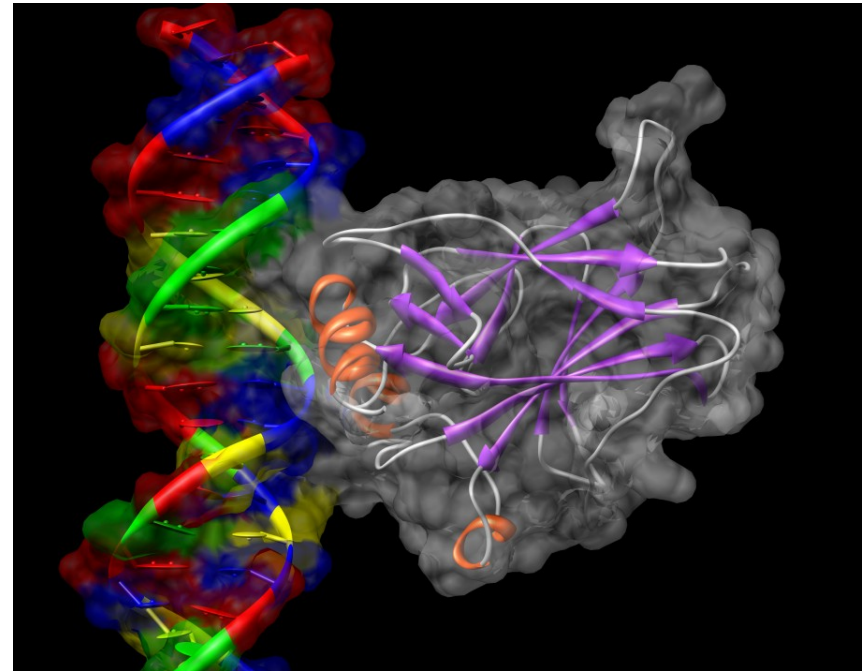

p53 core domain bound to DNA

Image Generated with UCSF Chimera

Cho, Y., Gorina, S., Jeffrey, P.D., Pavletich, N.P. Crystal structure of a p53 tumor suppressor-DNA complex: understanding tumorigenic mutations. *Science* v265 pp.346-355, 1994

Active Learning for Biological Discovery

Thanks to
Richard Lathrop

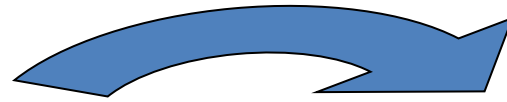
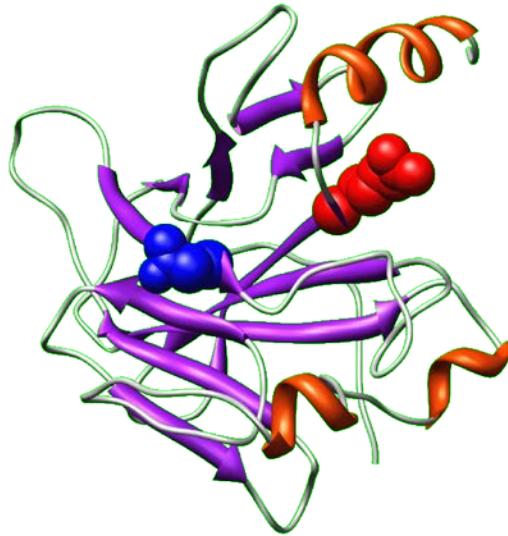

**Find Cancer
Rescue
Mutants**

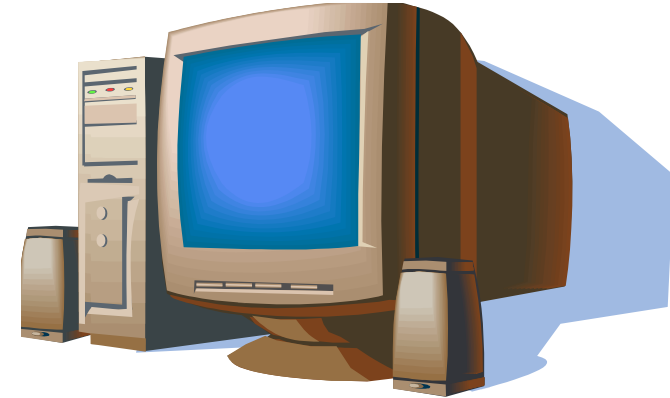

Knowledge

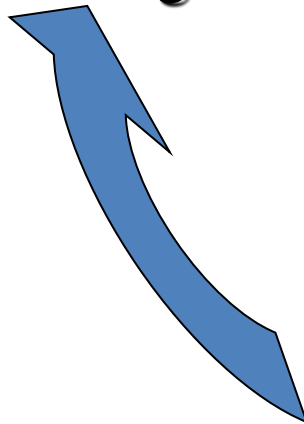

Theory

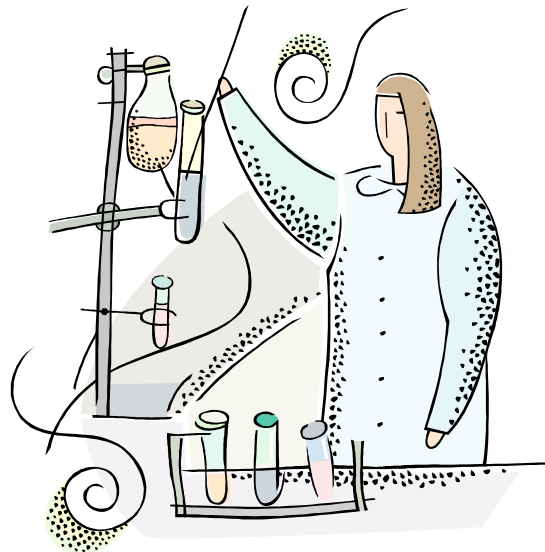
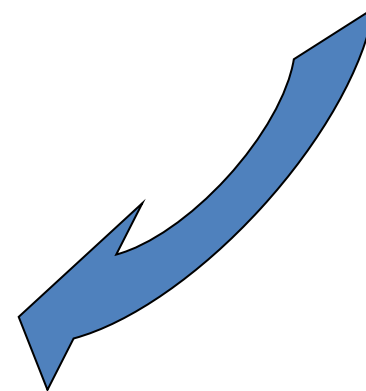

Experiment

Computational Active Learning

Pick the Best (= Most Informative) Unknown Examples to Label

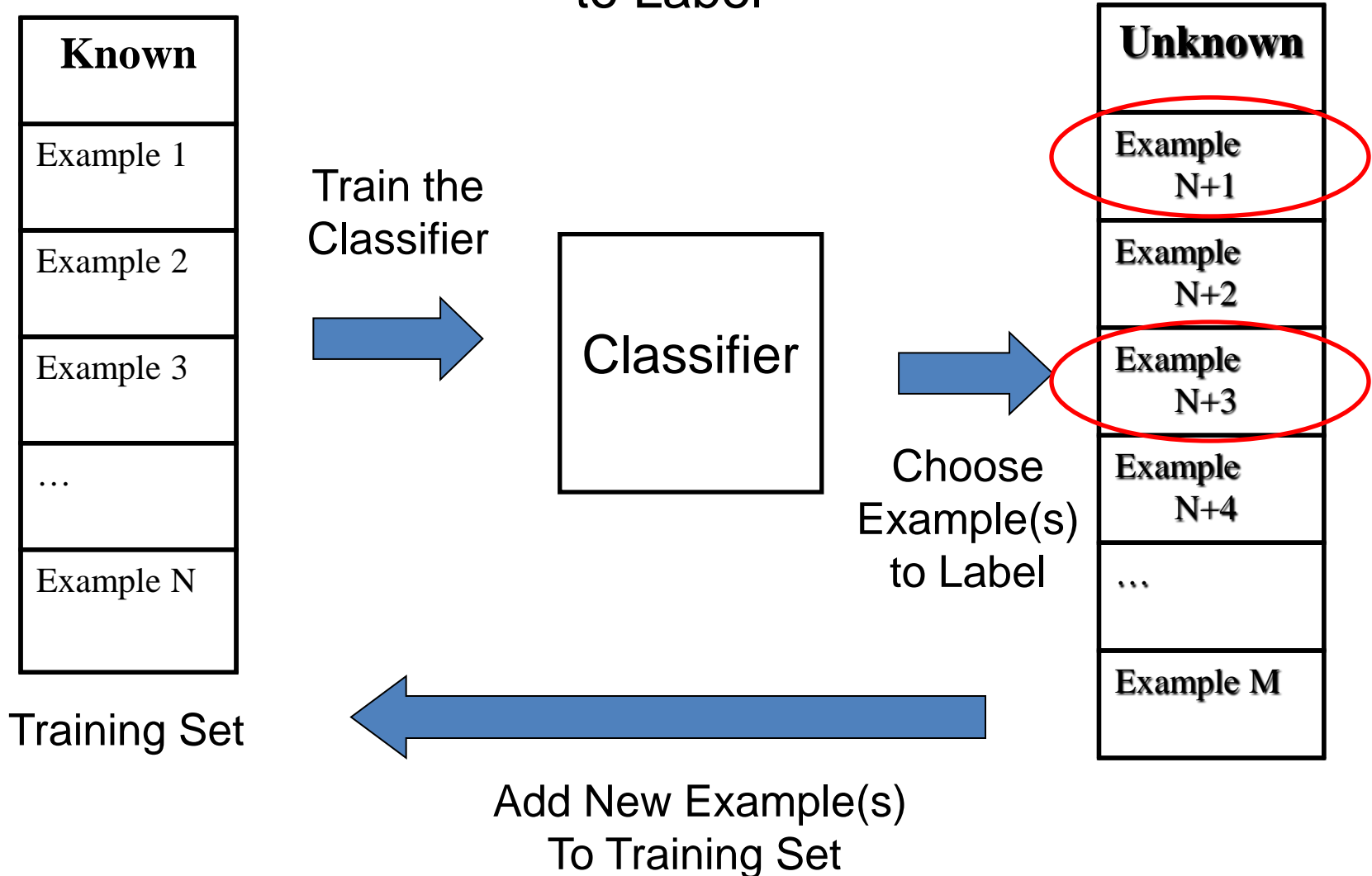

Visualization of Selected Regions

- **Positive Region:**
Predicted Active
96-105 (Green)
- **Negative Region:**
Predicted Inactive
223-232 (Red)
- **Expert Region:**
Predicted Active
114-123 (Blue)



Thanks to
Richard Lathrop

Novel Single-a.a. Cancer Rescue Mutants

Thanks to
Richard Lathrop

	MIP Positive (96-105)	MIP Negative (223-232)	Expert (114-123)
# Strong Rescue	8	0 (p < 0.008)	6 (not significant)
# Weak Rescue	3	2 (not significant)	7 (not significant)
Total # Rescue	11	2 (p < 0.022)	13 (not significant)

No significant differences between the MIP Positive and Expert regions.

Both were statistically significantly better than the MIP Negative region.

The Positive region rescued for the first time the cancer mutant P152L.

No previous single-a.a. rescue mutants in any region.

Complete architectures for intelligence?

- Search?
 - Solve the problem of what to do.
- Logic and inference?
 - Reason about what to do.
 - Encoded knowledge/“expert” systems?
 - Know what to do.
- Learning?
 - Learn what to do.
- Modern view: It’s complex & multi-faceted.

Automated Learning



- Why learn?
 - Key to intelligence
 - Take real data → get feedback → improve performance → reiterate
 - USC Autonomous Flying Vehicle Project
- Types of learning
 - Supervised learning: learn mapping: attributes → “target”
 - Classification: learn discreet target variable (e.g., spam email)
 - Regression: learn real valued target variable (e.g., stock market)
 - Unsupervised learning: no target variable; “understand” hidden data structure
 - Clustering: grouping data into K groups (e.g. K-means)
 - Latent space embedding: learn simple representation of the data (e.g. PCA, SVD)
 - Other types of learning
 - Reinforcement learning: e.g., game-playing agent
 - Learning to rank, e.g., document ranking in Web search
 - And many others....

Unsupervised Learning

Finding hidden structure in unlabeled data

Principal Component Analysis

PCA

$$\mathbf{T} = \mathbf{X}\mathbf{W}$$

\mathbf{X} is a m -by- n matrix, where n columns represent attributes and m rows represent samples

\mathbf{W} is a m -by- m matrix whose columns are the eigenvectors of $\mathbf{X}^T\mathbf{X}$

\mathbf{T} is eigenvalue decomposition of a data covariance matrix

- Explains variance in the data via principle components

Domestication in Crops

Principle Component Analysis (PCA) in Biology

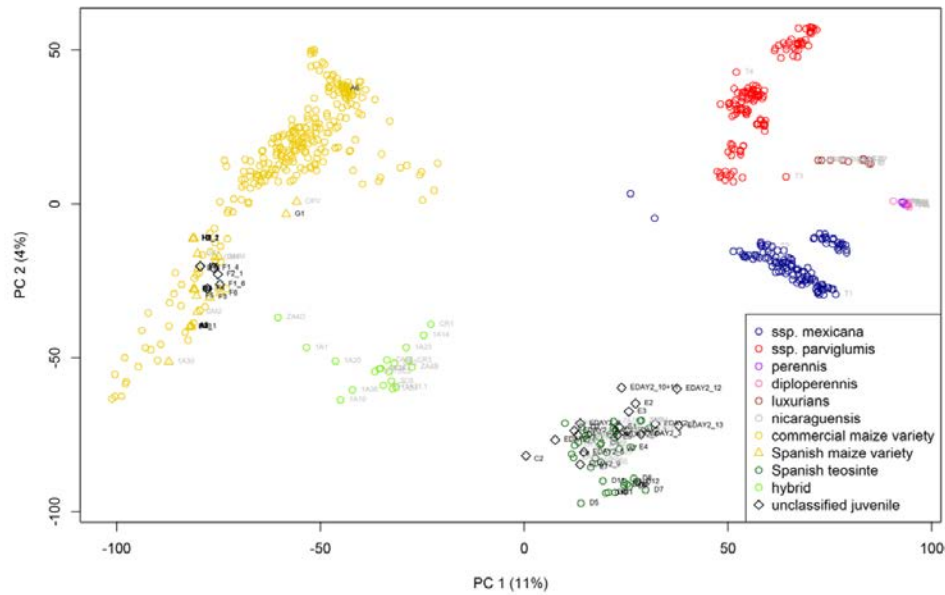

Maize
Trtikova et al, 2017

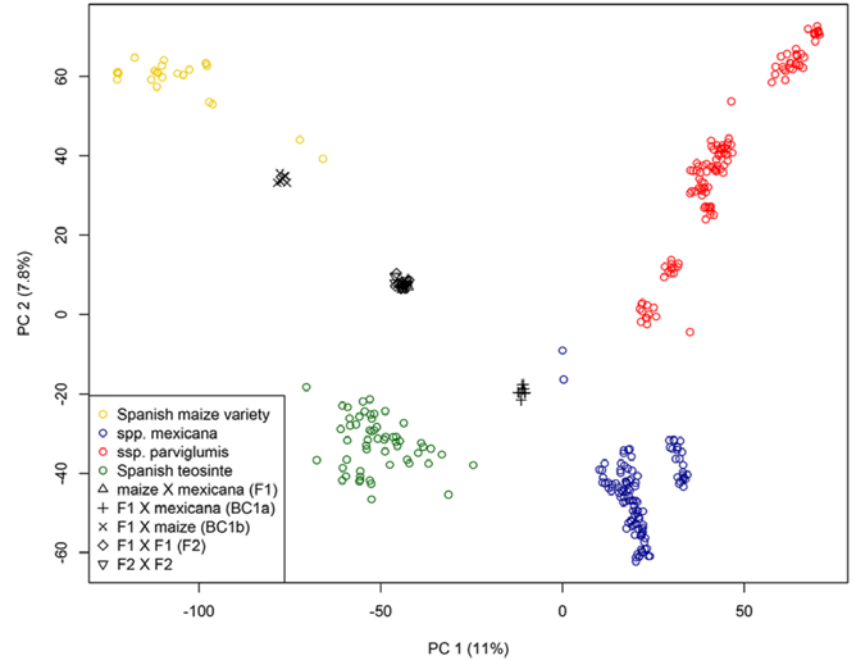

Maize
Trtikova et al, 2017

Domestication in Crops

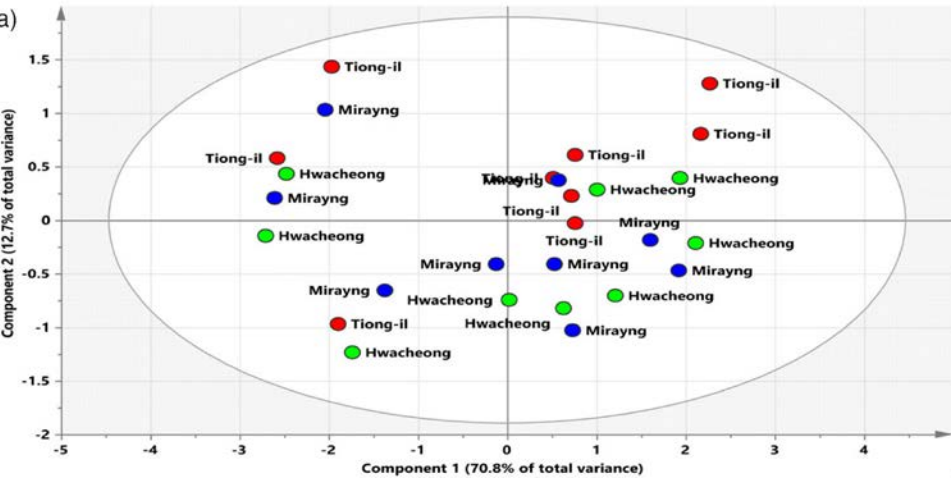

Rice
Chung et al, 2015

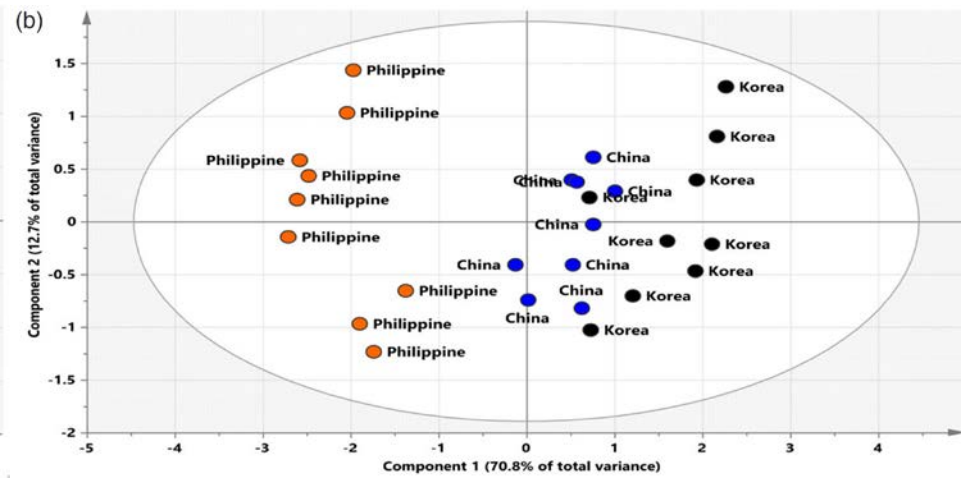

Rice
Chung et al, 2015

Domestication in Crops

Principle Component Analysis (PCA) + K-means Clustering

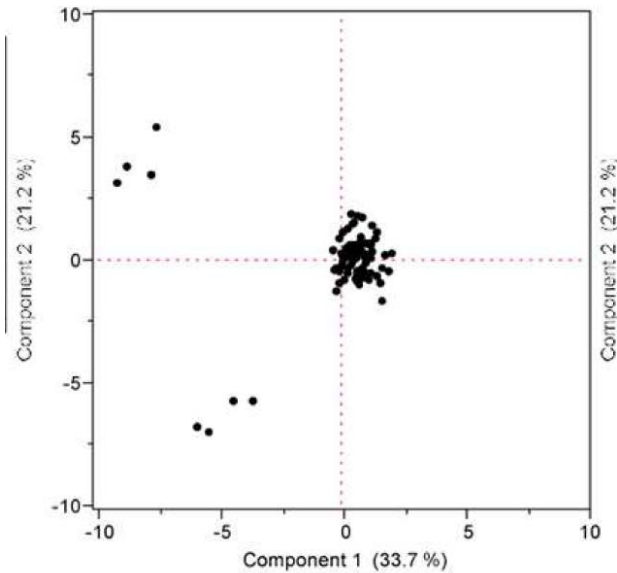

Rice
Kanapeckas et al, 2016

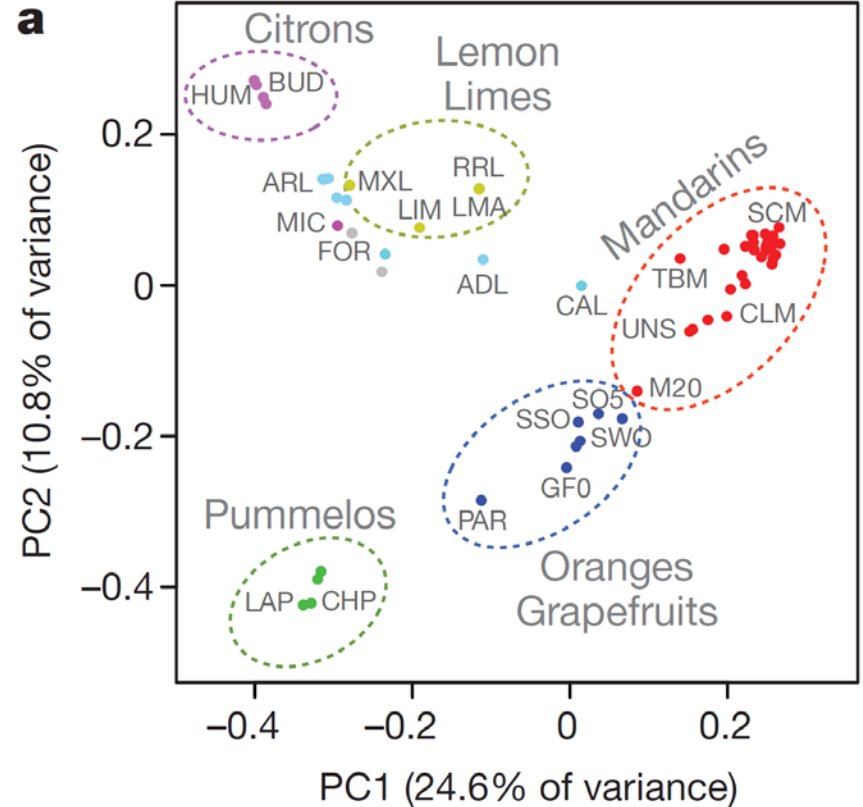

Citrus
Wu et al, 2018

Clustering

Unsupervised Learning

Thanks to
Padhraic Smyth

Application to Extra-Tropical Cyclones

Gaffney et al, *Climate Dynamics*, 2007

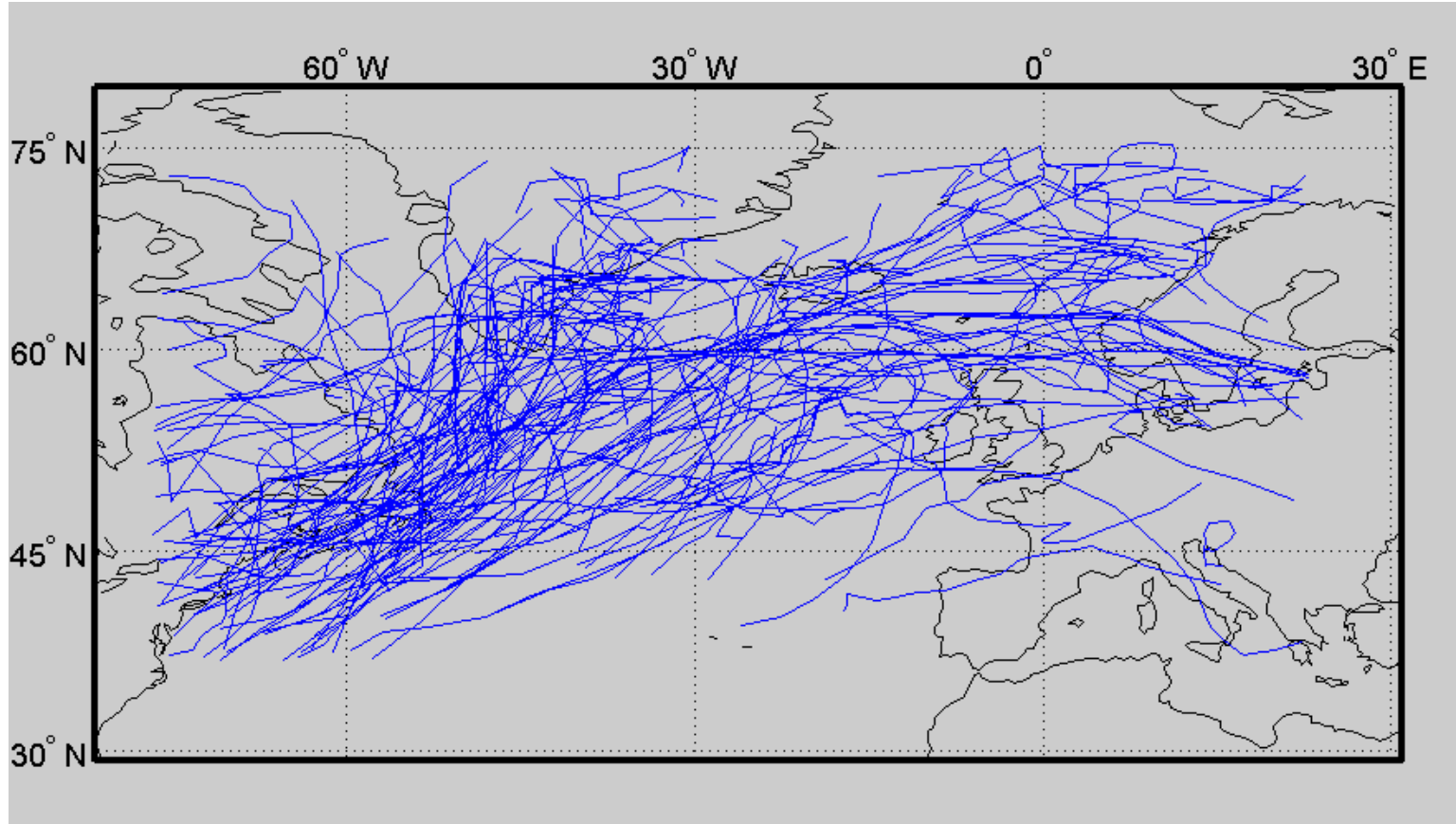

Thanks to
Padhraic Smyth

Original Data

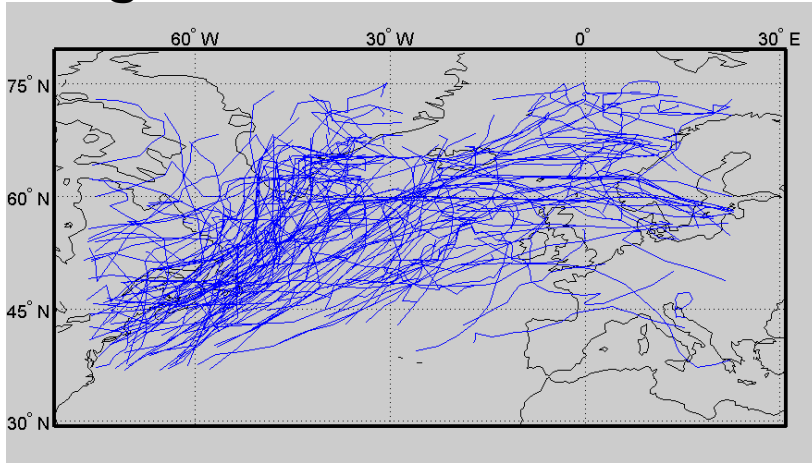

Iceland Cluster

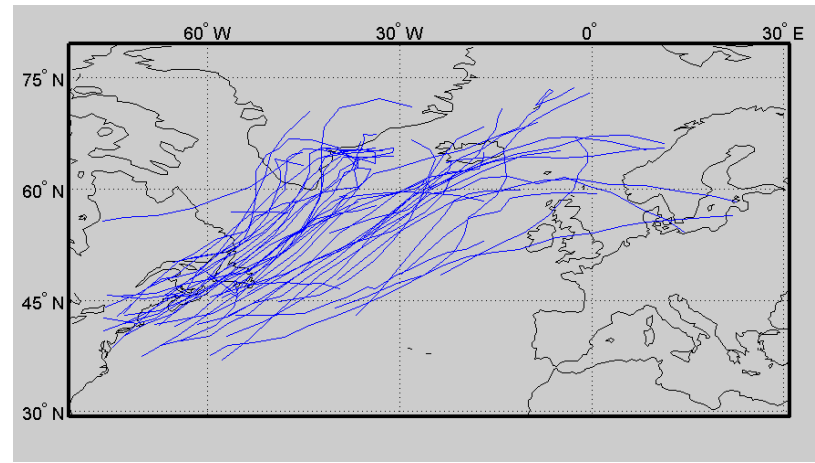

Greenland Cluster

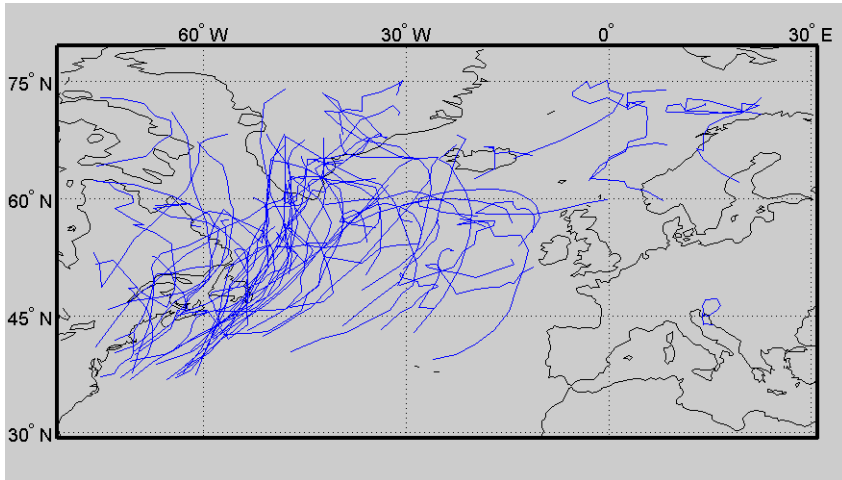

Horizontal Cluster

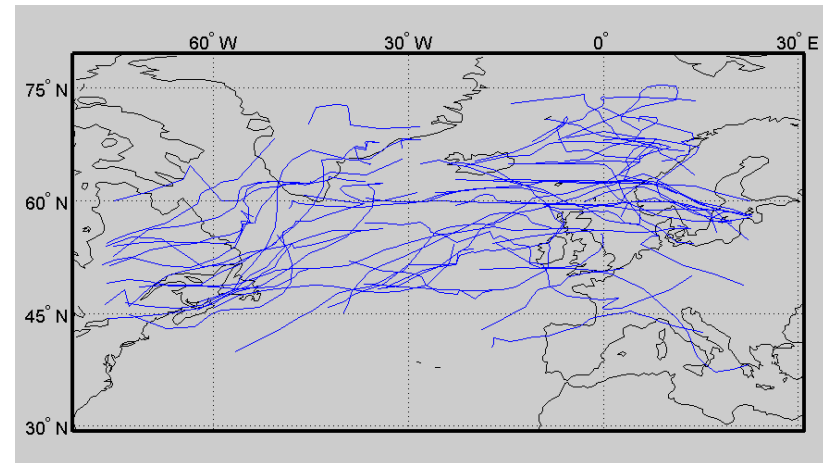

Thanks to
Padhraic Smyth

Cluster Shapes for Pacific Typhoon Tracks

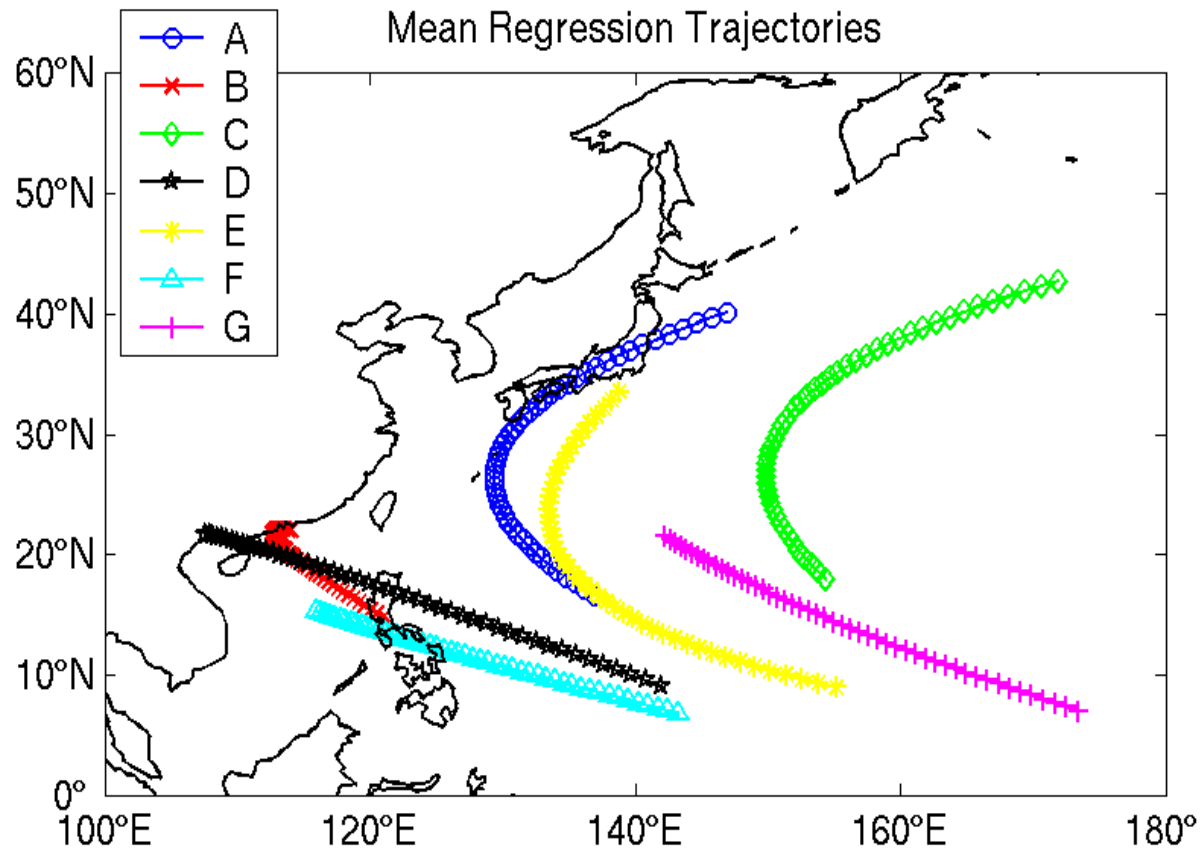

Thanks to
Padhraic Smyth

TROPICAL CYCLONES Western North Pacific

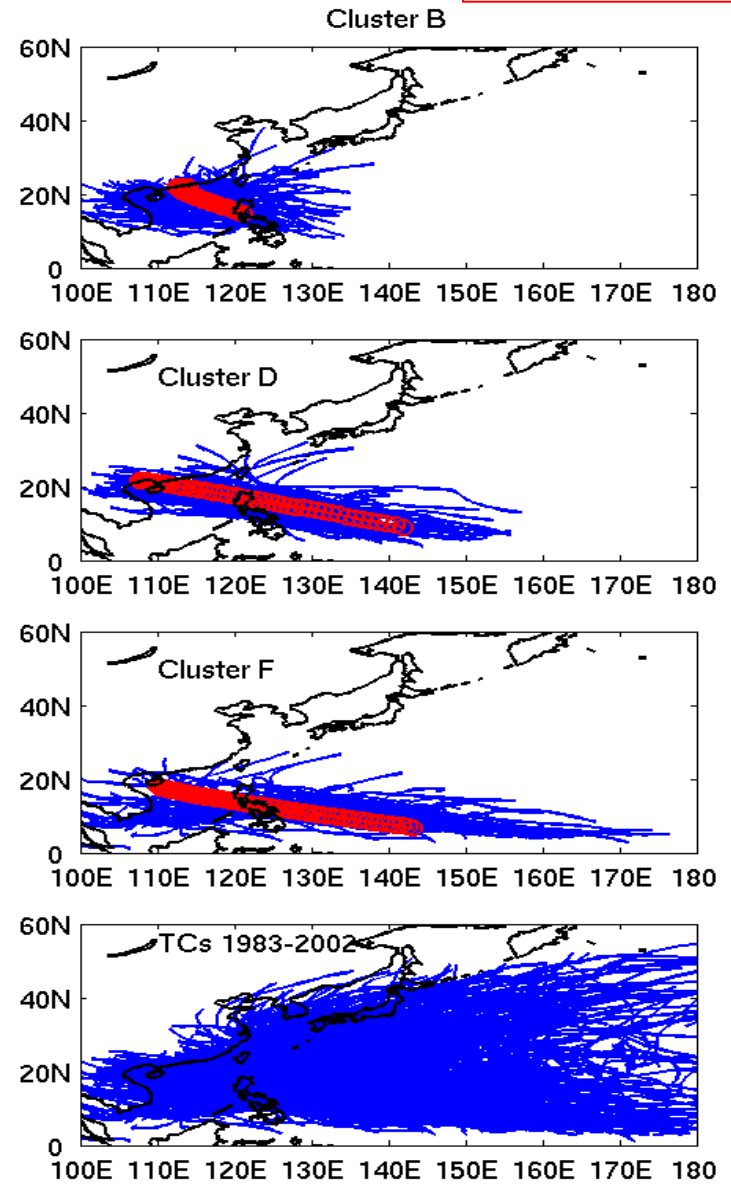
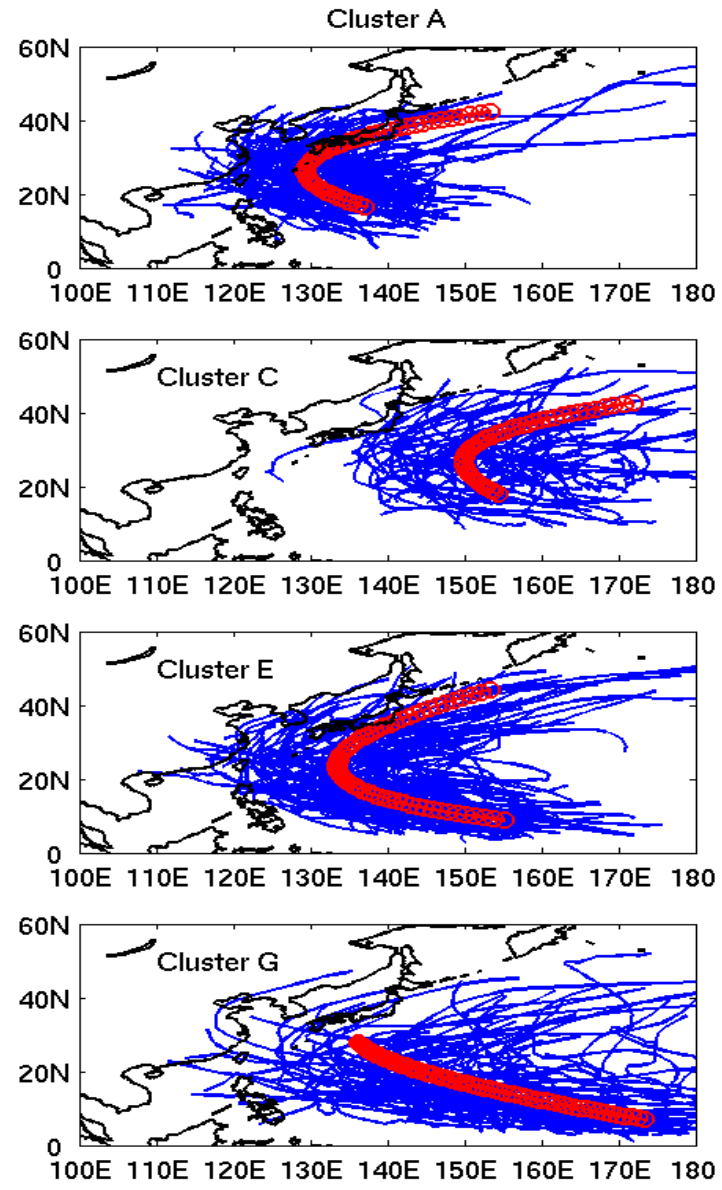

Thanks to
Padhraic Smyth

An ICS Undergraduate Success Story

“The key student involved in this work started out as an **ICS undergrad**. **Scott Gaffney** took **ICS 171 and 175**, got interested in AI, started to work in my group, decided to stay in ICS for his PhD, did a terrific job in writing a thesis on curve-clustering and working with collaborators in climate science to apply it to important scientific problems, and is now **one of the leaders of Yahoo! Labs** reporting directly to the CEO there, <http://labs.yahoo.com/author/gaffney/>. Scott grew up locally in Orange County and is someone I like to point as a great **success story for ICS**.”

--- From Padhraic Smyth

Supervised Learning

Inference made by learning from labeled training data

Computer Vision

Classification

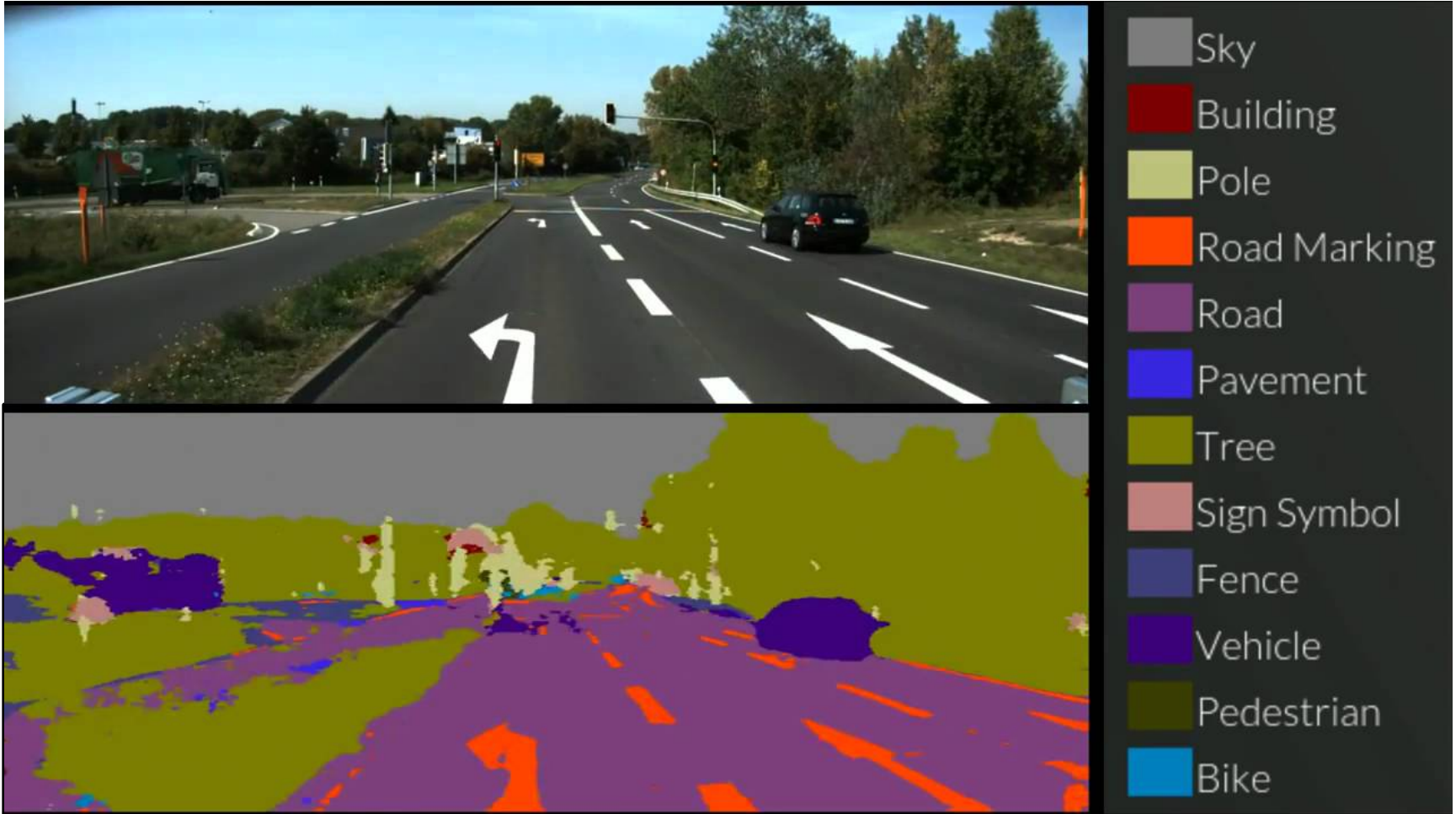

Courtesy of Nvidia
Website

Computer Vision

Classification



NVIDIA DRIVE™ PX DEEP NEURAL NETWORK COMPUTER VISION

Courtesy of Nvidia
Website

Computer Vision

PEAS = Performance Measure, Environment, Actuators, and Sensors

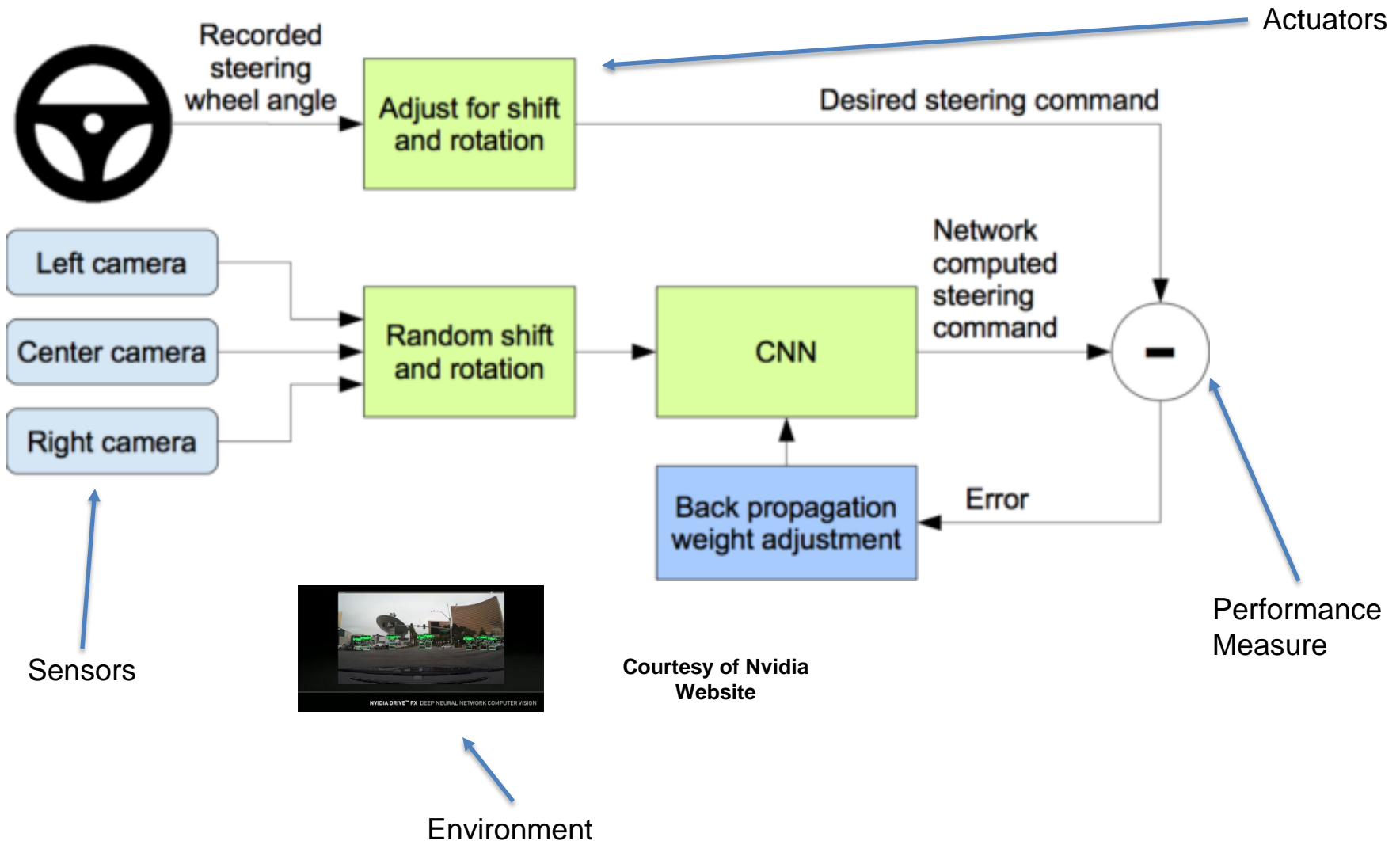

Deep Learning

Example Neural Net

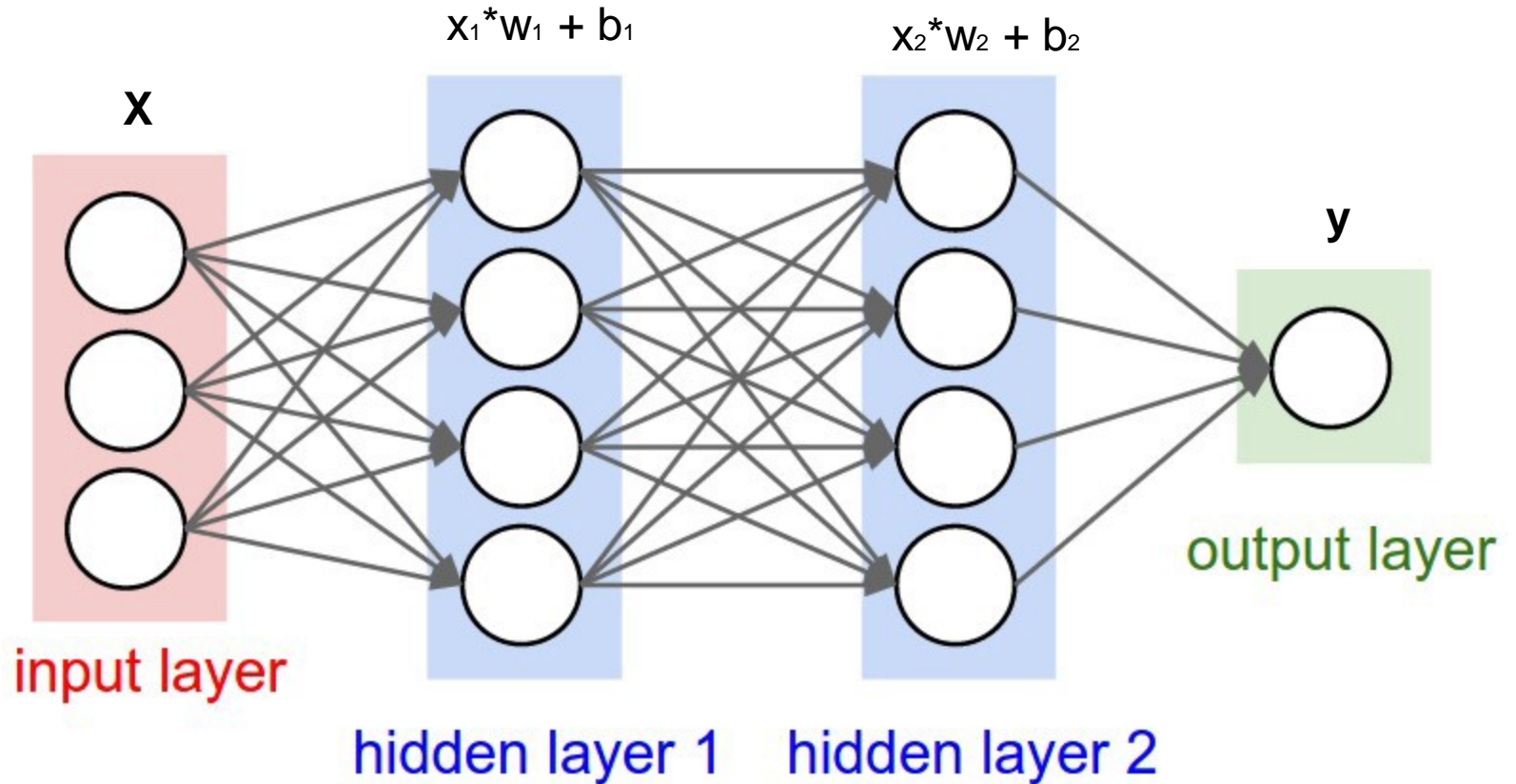

Courtesy of Nvidia
Website

Neurons

1st Generation Neuron (McCulloch-Pitts)

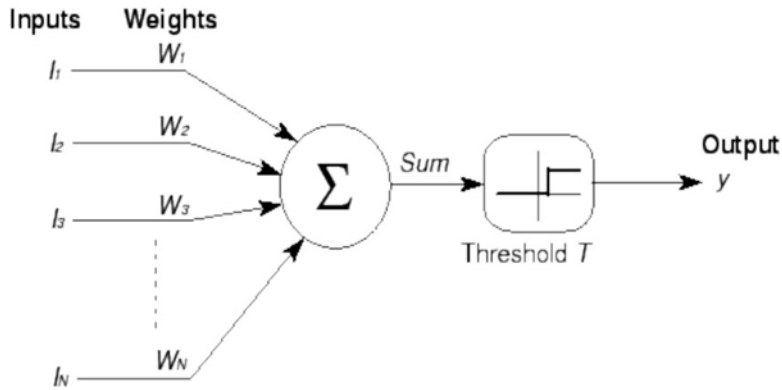

3rd Generation Neuron (Spiking Neurons)

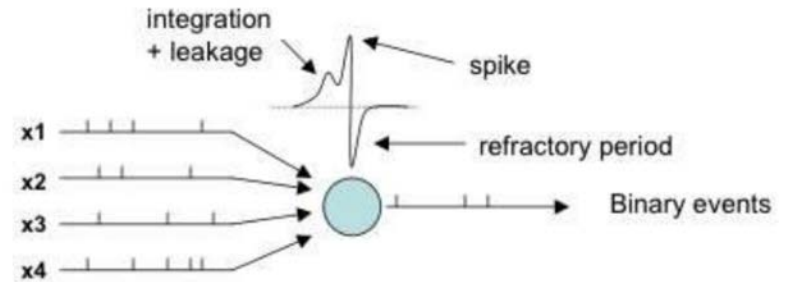

2nd Generation Neuron

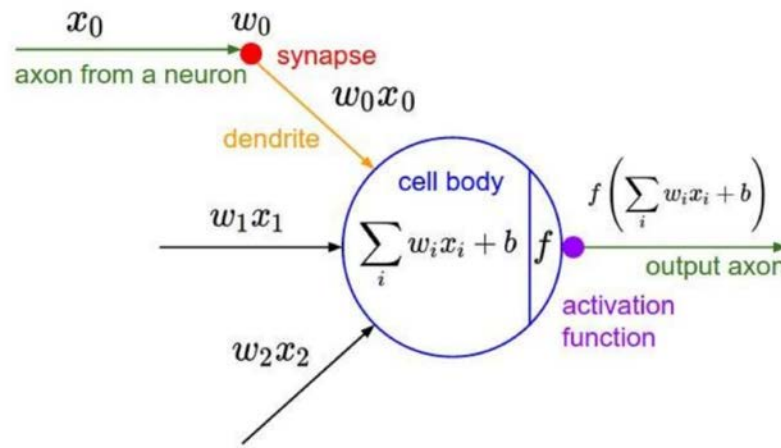

Hodgkin-Huxley Model

Izhikevich Model

Leakage Integrate-and-Fire Model

Deep Learning

Example of Best Price using Deep Neural Net (Deep Learning)

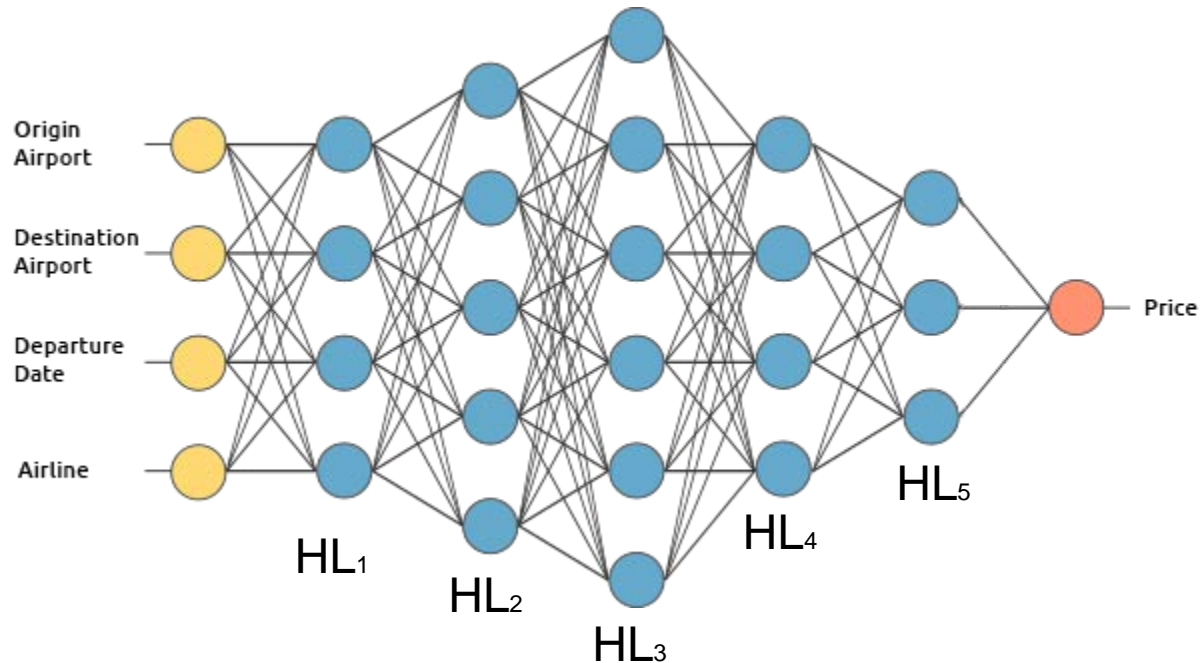

Courtesy of Nvidia
Website

Computer Vision

Increasing computational power

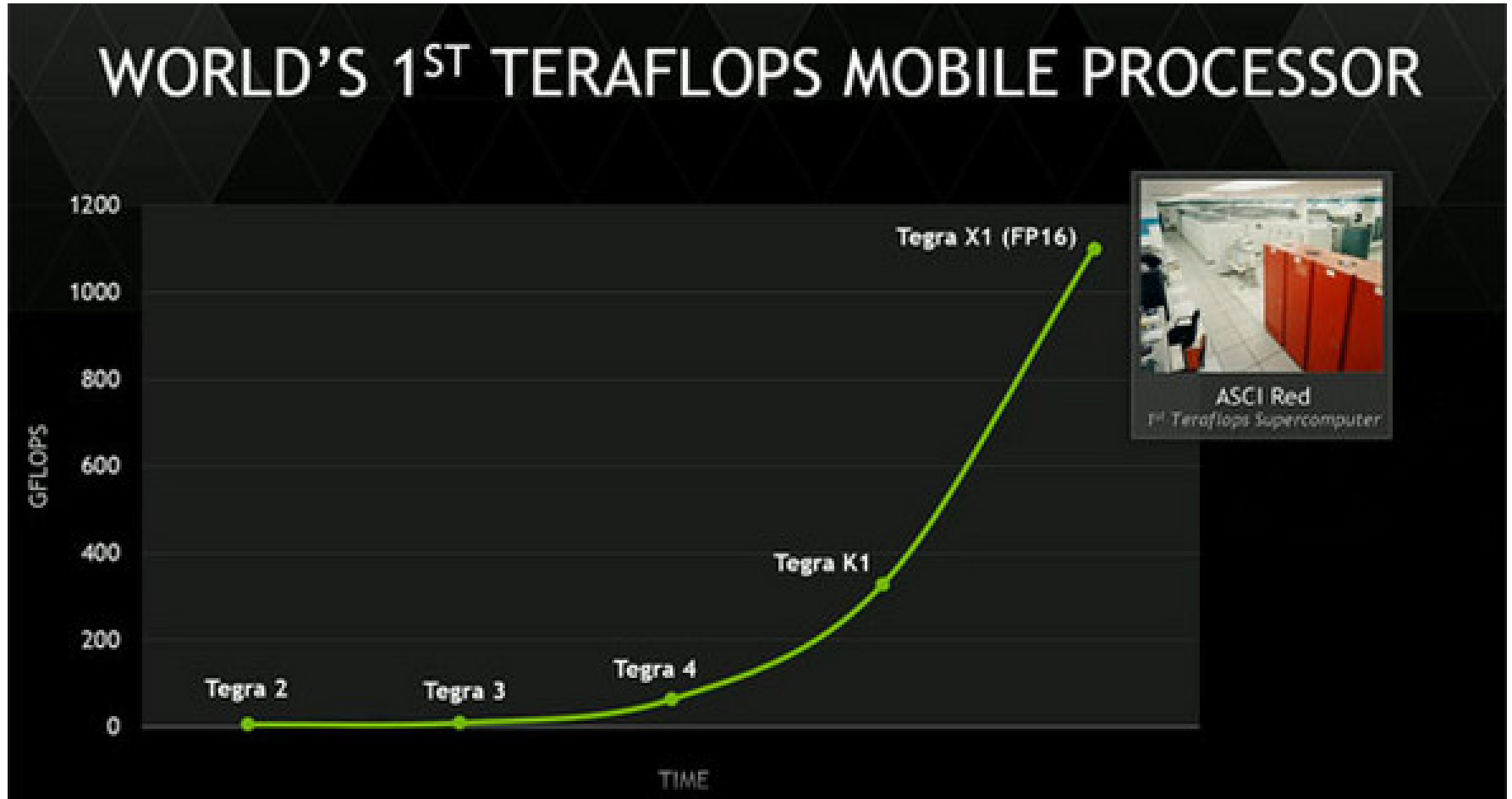

Courtesy of Nvidia
Website

Computer Vision

PEAS = Performance Measure, Environment, Actuators, and Sensors

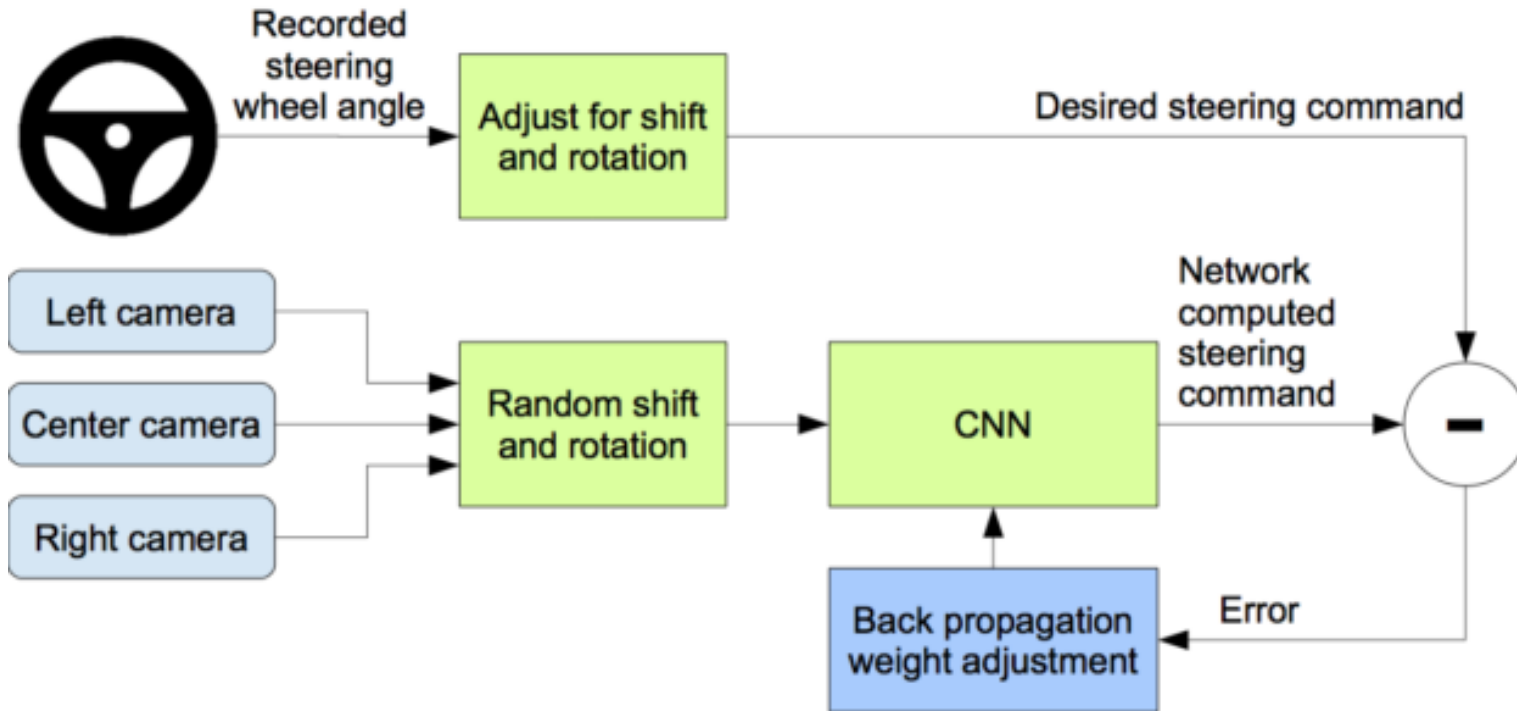

Courtesy of Nvidia
Website

Reward function
Utility gradient

Minimization of Cost Function

Gradient Decent

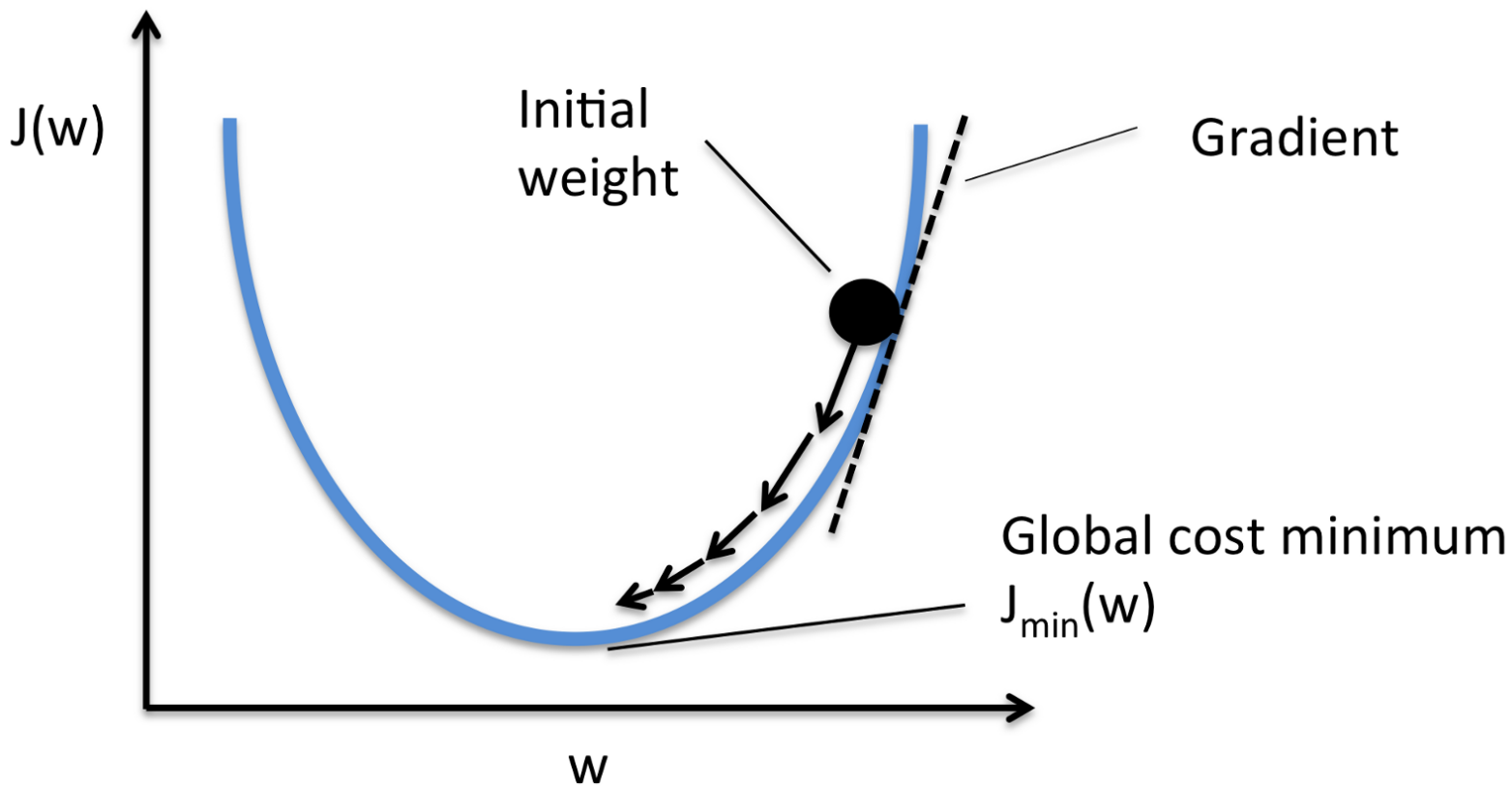

Courtesy of Nvidia
Website

Minimization of Cost Function

Gradient Decent

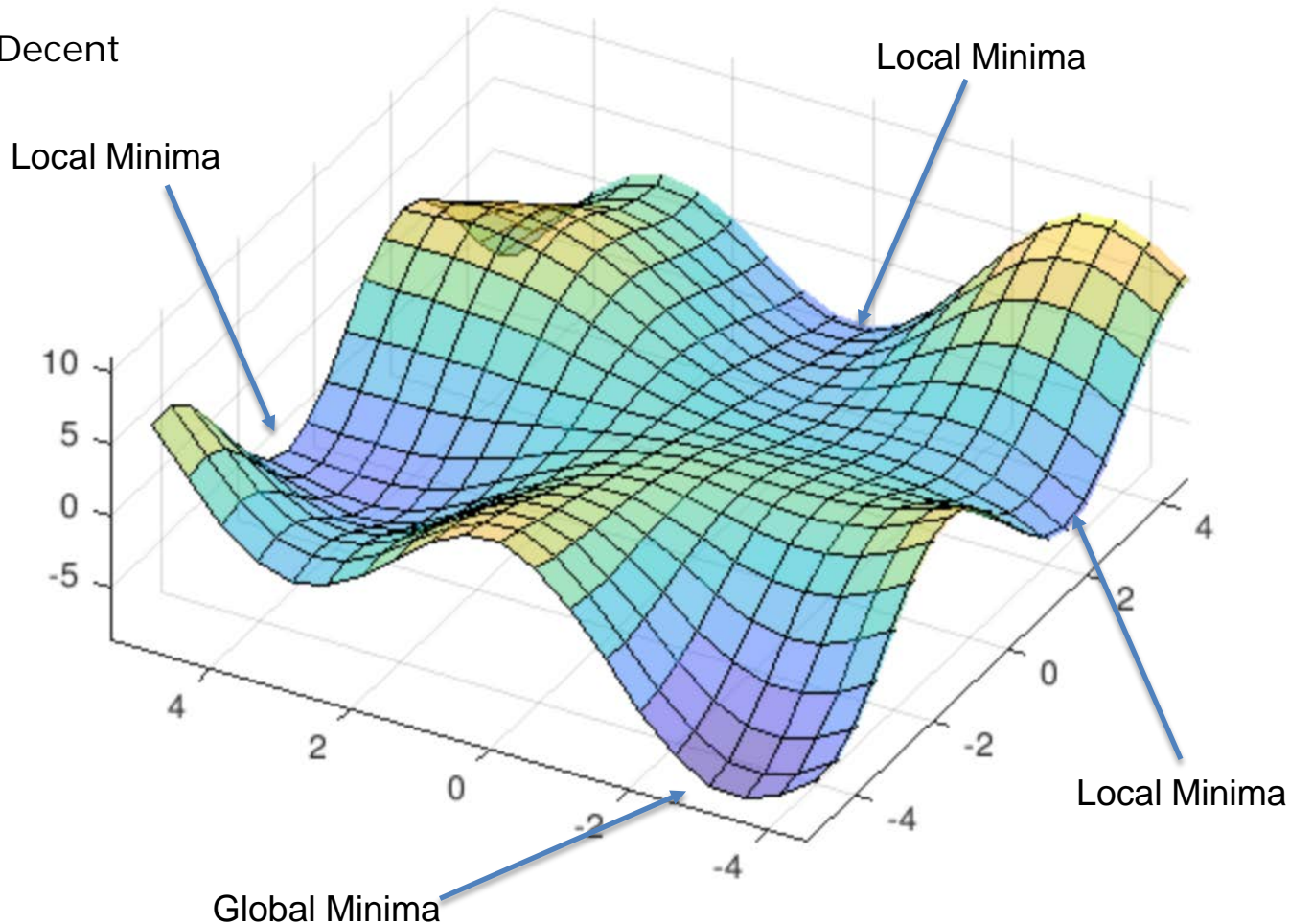

Entertaining and informative way to learn about Neural Nets and Deep Learning
<https://www.youtube.com/watch?v=p69khggr1Jo>

Deep Learning in Physics: Searching for Exotic Particles

Thanks to
Pierre Baldi

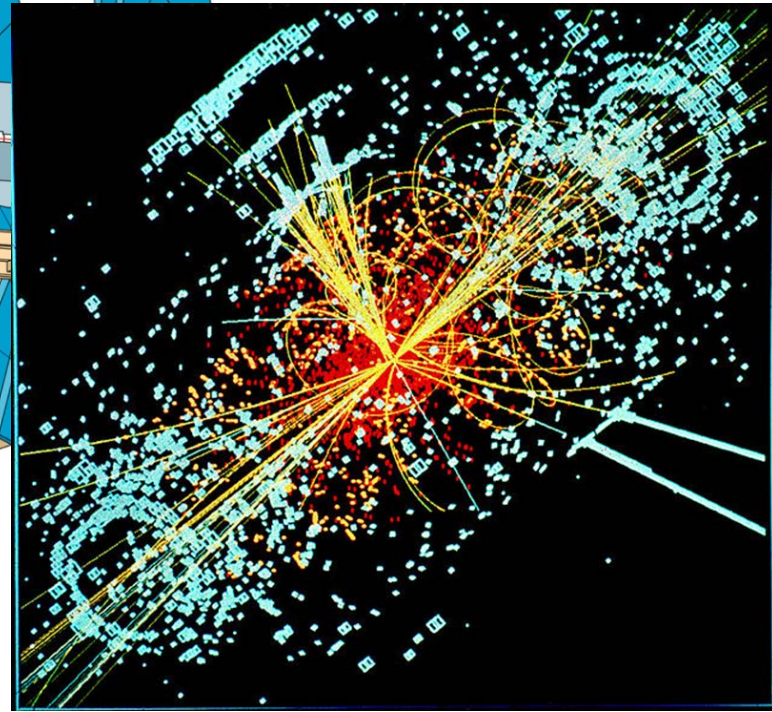
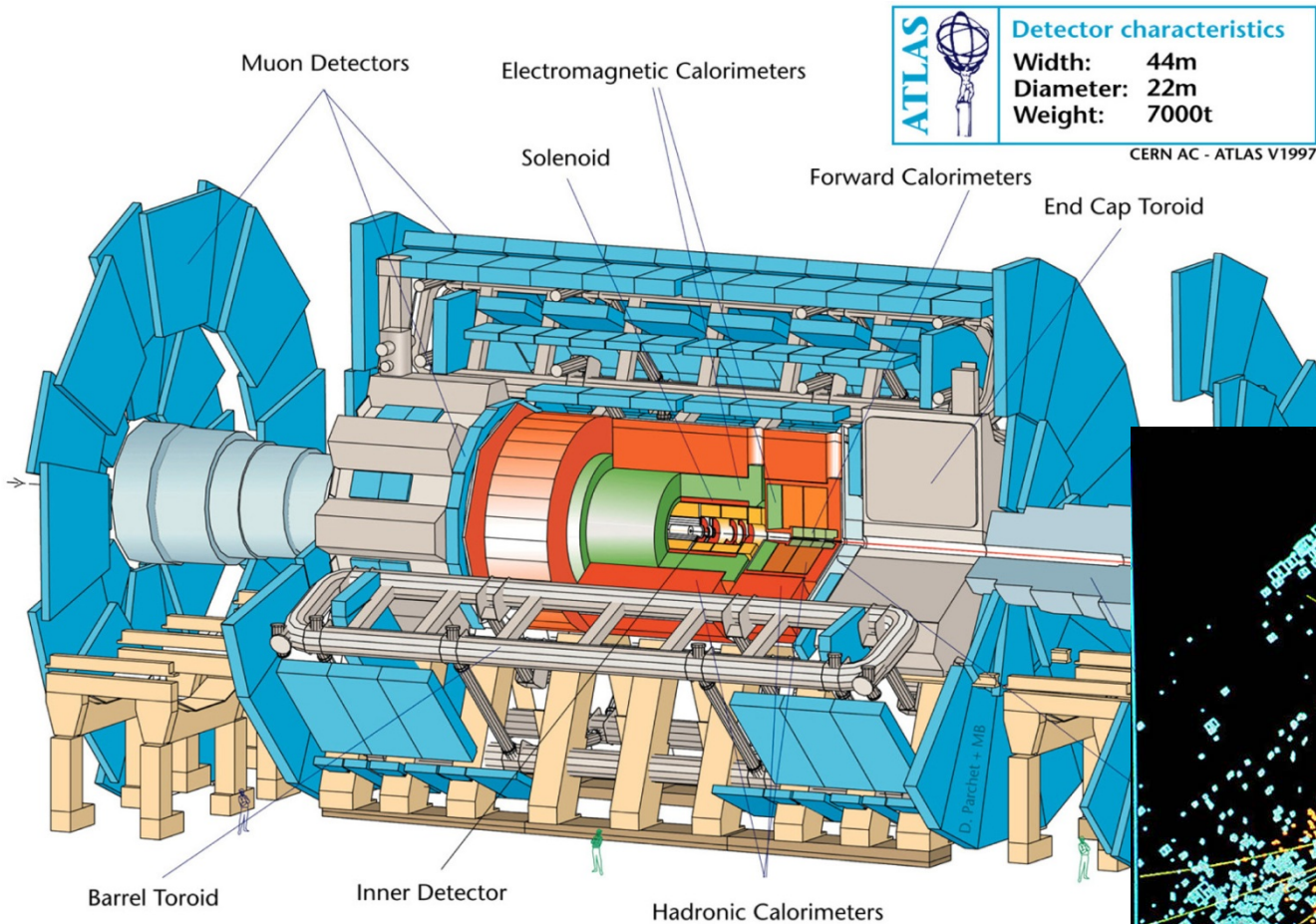

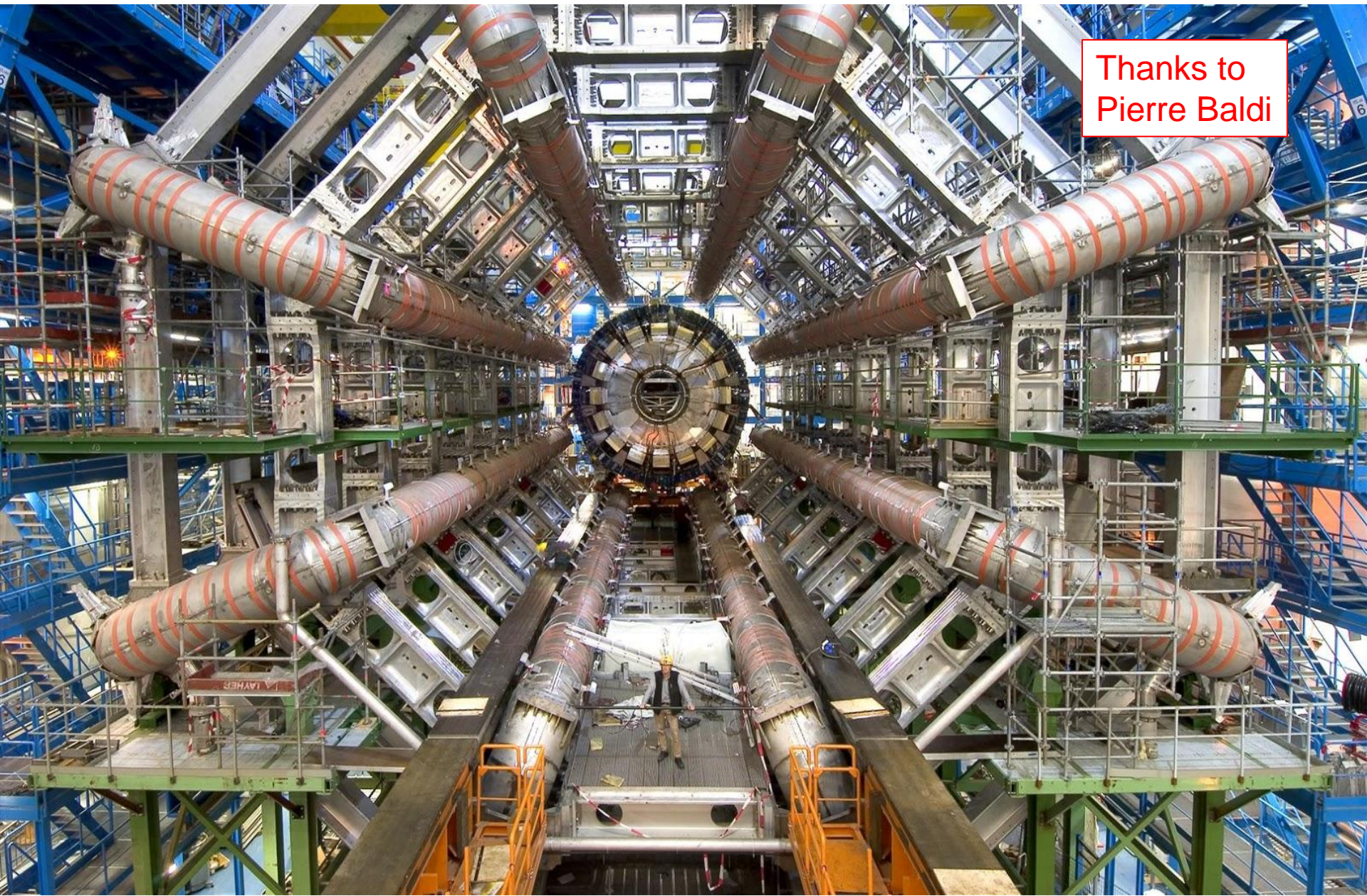

Thanks to
Pierre Baldi

ARTICLE

Received 19 Feb 2014 | Accepted 4 Jun 2014 | Published 2 Jul 2014

DOI: 10.1038/ncomms5308

Searching for exotic particles in high-energy physics with deep learning

P. Baldi¹, P. Sadowski¹ & D. Whiteson²

Collisions at high-energy particle colliders are a traditionally fruitful source of exotic particle discoveries. Finding these rare particles requires solving difficult signal-versus-background classification problems, hence machine-learning approaches are often used. Standard approaches have relied on 'shallow' machine-learning models that have a limited capacity to learn complex nonlinear functions of the inputs, and rely on a painstaking search through manually constructed nonlinear features. Progress on this problem has slowed, as a variety of techniques have shown equivalent performance. Recent advances in the field of deep learning make it possible to learn more complex functions and better discriminate between signal and background classes. Here, using benchmark data sets, we show that deep-learning methods need no manually constructed inputs and yet improve the classification metric by as much as 8% over the best current approaches. This demonstrates that deep-learning approaches can improve the power of collider searches for exotic particles.



Daniel Whiteson



Peter Sadowski

Higgs Boson Detection

Thanks to
Pierre Baldi

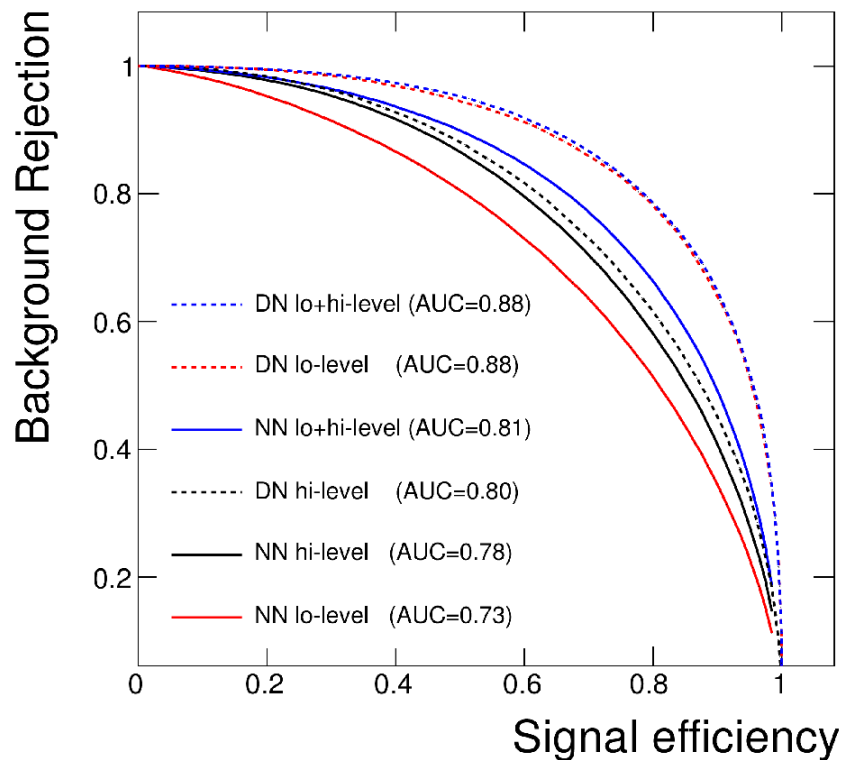

Technique	AUC		
	Low-level	High-level	Complete
BDT	0.73	0.78	0.81
NN	0.733 (0.007)	0.777 (0.001)	0.816 (0.004)
DN	0.880 (0.001)	0.800 (< 0.001)	0.885 (0.002)

BDT= Boosted Decision Trees in TMVA package

Deep network improves AUC by 8%

Supervised Learning

Definitions and Properties

Terminology

- Attributes
 - Also known as features, variables, independent variables, covariates
- Target Variable
 - Also known as goal predicate, dependent variable, $f(x)$, y ...
- Classification
 - Also known as discrimination, supervised classification, ...
- Error function
 - Objective function, loss function, ...

Supervised learning

- Let x = input vector of attributes (feature vectors)
- Let $f(x)$ = target label
 - The implicit mapping from x to $f(x)$ is unknown to us
 - We only have training data pairs, $D = \{\mathbf{x}, \mathbf{f}(\mathbf{x})\}$ available
- We want to learn a mapping from x to $f(x)$
 - Our hypothesis function is $h(x, \theta)$
 - $h(x, \theta) \approx f(x)$ for all training data points x
 - θ are the parameters of our predictor function h
- Examples:
 - $h(x, \theta) = \text{sign}(\theta_1 x_1 + \theta_2 x_2 + \theta_3)$ (perceptron)
 - $h(x, \theta) = \theta_0 + \theta_1 x_1 + \theta_2 x_2$ (regression)
 - $h_k(x) = (x_1 \wedge x_2) \vee (x_3 \wedge \neg x_4)$

Empirical Error Functions

- $E(h) = \sum_x \text{distance}[h(x, \theta), f(x)]$

Sum is over all training pairs in the training data D

Examples:

distance = squared error if h and f are real-valued (regression)

distance = delta-function if h and f are categorical (classification)

In learning, we get to choose

1. what class of functions $h(\cdot)$ that we want to learn
 - potentially a huge space! (“hypothesis space”)
2. what error function/distance to use
 - should be chosen to reflect real “loss” in problem
 - but often chosen for mathematical/algorithmic convenience

Inductive Learning as Optimization or Search

- Empirical error function:

$$E(h) = \sum_x \text{distance}[h(x, \theta), f(x)]$$

- Empirical learning = finding $h(x)$, or $h(x; \theta)$ that minimizes $E(h)$
 - In simple problems there may be a closed form solution
 - E.g., “normal equations” when h is a linear function of x , E = squared error
 - If $E(h)$ is **differentiable** \rightarrow continuous optimization problem using gradient descent, etc
 - E.g., multi-layer neural networks
 - If $E(h)$ is **non-differentiable** (e.g., classification \rightarrow systematic search problem through the *space of functions h*)
 - E.g., decision tree classifiers
- Once we decide on what the functional form of h is, and what the error function E is, then machine learning typically reduces to a large search or optimization problem
- Additional aspect: we really want to learn a function h that will generalize well to new data, not just memorize training data – will return to this later

Simple illustrative learning problem

Problem:

decide whether to wait for a table at a restaurant, based on the following attributes:

1. Alternate: is there an alternative restaurant nearby?
2. Bar: is there a comfortable bar area to wait in?
3. Fri/Sat: is today Friday or Saturday?
4. Hungry: are we hungry?
5. Patrons: number of people in the restaurant (None, Some, Full)
6. Price: price range (\$, \$\$, \$\$\$)
7. Raining: is it raining outside?
8. Reservation: have we made a reservation?
9. Type: kind of restaurant (French, Italian, Thai, Burger)
10. WaitEstimate: estimated waiting time (0-10, 10-30, 30-60, >60)

Is it a weekend? Hungry? Busy? Cost? Wait time? Etc...

Example Training Data

Example	Attributes										Target
	<i>Alt</i>	<i>Bar</i>	<i>Fri</i>	<i>Hun</i>	<i>Pat</i>	<i>Price</i>	<i>Rain</i>	<i>Res</i>	<i>Type</i>	<i>Est</i>	<i>Wait</i>
X_1	T	F	F	T	Some	\$\$\$	F	T	French	0-10	T
X_2	T	F	F	T	Full	\$	F	F	Thai	30-60	F
X_3	F	T	F	F	Some	\$	F	F	Burger	0-10	T
X_4	T	F	T	T	Full	\$	F	F	Thai	10-30	T
X_5	T	F	T	F	Full	\$\$\$	F	T	French	>60	F
X_6	F	T	F	T	Some	\$\$	T	T	Italian	0-10	T
X_7	F	T	F	F	None	\$	T	F	Burger	0-10	F
X_8	F	F	F	T	Some	\$\$	T	T	Thai	0-10	T
X_9	F	T	T	F	Full	\$	T	F	Burger	>60	F
X_{10}	T	T	T	T	Full	\$\$\$	F	T	Italian	10-30	F
X_{11}	F	F	F	F	None	\$	F	F	Thai	0-10	F
X_{12}	T	T	T	T	Full	\$	F	F	Burger	30-60	T

- If all attributes were binary, $h(\cdot)$ could be any arbitrary Boolean function
- Natural error function $E(h)$ to use is classification error, i.e., how many incorrect predictions does a hypothesis h make
- Note an implicit assumption:
 - For any set of attribute values there is a unique target value
 - This in effect assumes a “no-noise” mapping from inputs to targets
 - This is often not true in practice (e.g., in medicine).

Supervised Learning

Decision Trees

Learning Boolean Functions

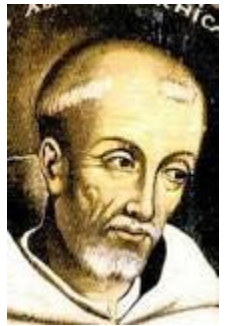

William of Ockham
c. 1288-1347

- Given examples of the function, can we learn the function?
 $f: \mathbf{B}^d \rightarrow \mathbf{B}$ where $\mathbf{B} = \{0, 1\}$
- How many Boolean functions can be defined on **d attributes**?
 - Boolean function = Truth table + binary target column
 - Truth table 2^d rows + binary 2^d targets = 2^{2^d}
 - 2^{2^d} hypothesis search space
 - i.e. for $d = 6$, there are 1.84×10^{19} possible Boolean functions
- Observations:
 - Huge hypothesis spaces \rightarrow directly searching over all functions is impossible
 - Given a small data (n pairs) our learning problem may be under constrained
 - Ockham's razor: if multiple candidate functions all explain the data equally well, pick the simplest explanation (least complex function)
 - Constrain our search to classes of Boolean functions, i.e.,
 - decision trees
 - Weighted linear sums of inputs (e.g., perceptron's)

Decision Tree Representations

- Decision trees are fully expressive
 - can represent any Boolean function
 - Every path in the tree could represent 1 row in the truth table
 - Yields an exponentially large tree
 - Truth table with 2^d rows, where d is the number of attributes

A	B	A xor B
F	F	F
F	T	T
T	F	T
T	T	F

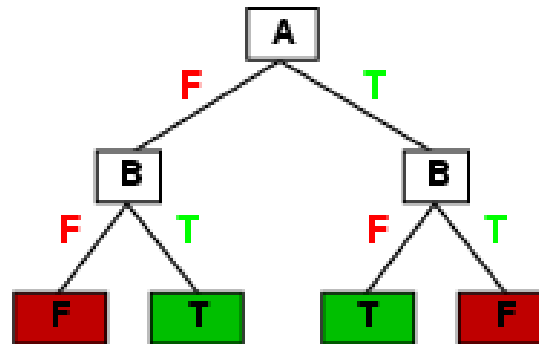

Decision Tree Representations

- Decision trees are DNF representations
 - often used in practice → result in compact approximate representations for complex functions
 - E.g., consider a truth table where most of the variables are irrelevant to the function
- Simple DNF formulae can be easily represented
 - E.g., $f = (A \wedge B) \vee (\neg A \wedge D)$
 - DNF = disjunction of conjunctions
- Trees can be very inefficient for certain types of functions
 - Parity function: 1 only if an even number of 1's in the input vector
 - Trees are very inefficient at representing such functions
 - Majority function: 1 if more than $\frac{1}{2}$ the inputs are 1's
 - Also inefficient

Decision Tree Learning

- Find the smallest decision tree consistent with the n examples
 - Not optimal
 - $n < d$
- Greedy heuristic search used in practice:
 - Select root node that is “best” in some sense
 - Partition data into 2 subsets, depending on root attribute value
 - Recursively grow subtrees
 - Different termination criteria
 - For noiseless data, if all examples at a node have the same label then declare it a leaf and backup
 - For noisy data it might not be possible to find a “pure” leaf using the given attributes
 - a simple approach is to have a depth-bound on the tree (or go to max depth) and use majority vote
- We have talked about binary variables up until now, but we can trivially extend to multi-valued variables

Pseudocode for Decision tree learning

```
function DTL(examples, attributes, default) returns a decision tree
  if examples is empty then return default
  else if all examples have the same classification then return the classification
  else if attributes is empty then return MODE(examples)
  else
    best ← CHOOSE-ATTRIBUTE(attributes, examples)
    tree ← a new decision tree with root test best
    for each value  $v_i$  of best do
       $examples_i$  ← {elements of examples with best =  $v_i$ }
      subtree ← DTL( $examples_i$ , attributes – best, MODE(examples))
      add a branch to tree with label  $v_i$  and subtree subtree
  return tree
```

Decision Tree Learning

Authors Created

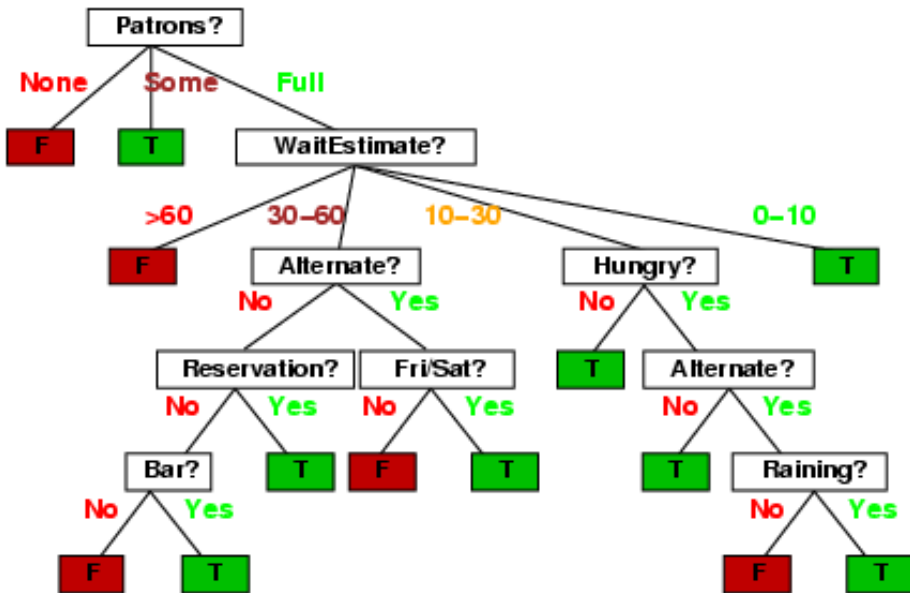

Choosing an attribute

- Idea: a good attribute splits the examples into subsets that are (ideally) "all positive" or "all negative"

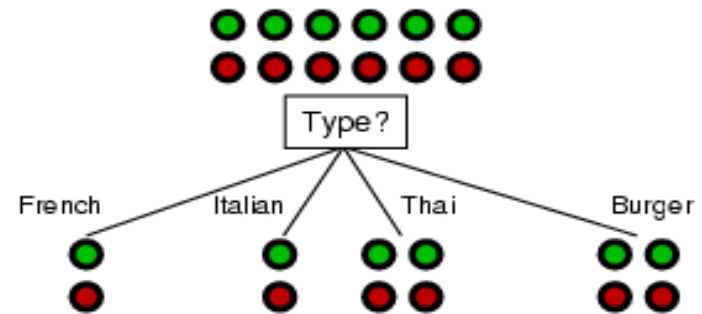
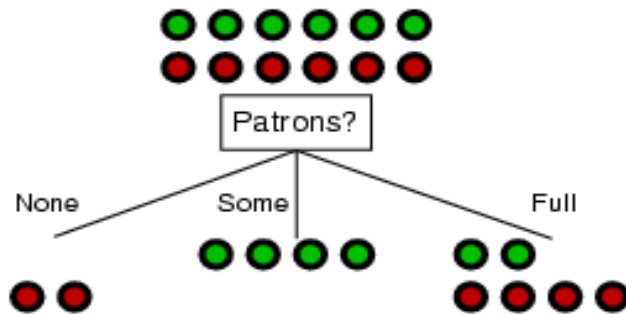

- Patrons?* is a better choice
 - How can we quantify this?
 - One approach would be to use the classification error E directly (greedily)
 - Empirically it is found that this works poorly
 - Much better is to use information gain (next slides)

Entropy and Information

- “Entropy” is a measure of randomness
- In chemistry:

If the particles represent gas molecules at normal temperatures inside a closed container, which of the illustrated configurations came first?

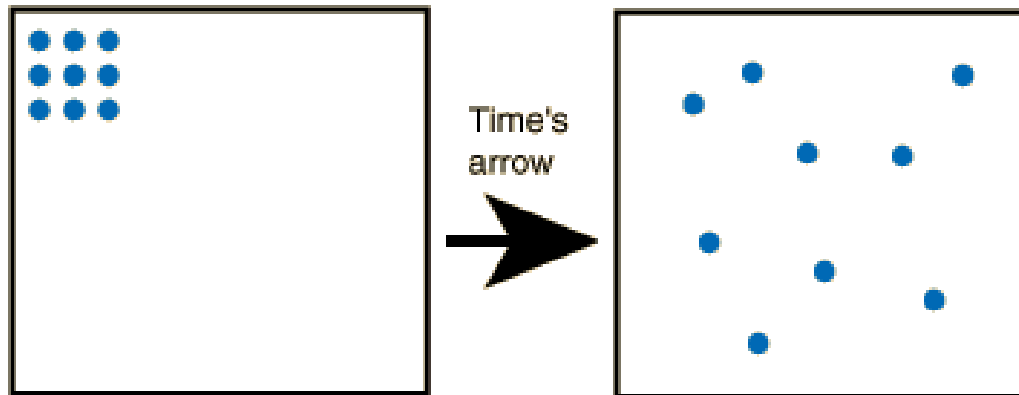

If you tossed bricks off a truck, which kind of pile of bricks would you more likely produce?

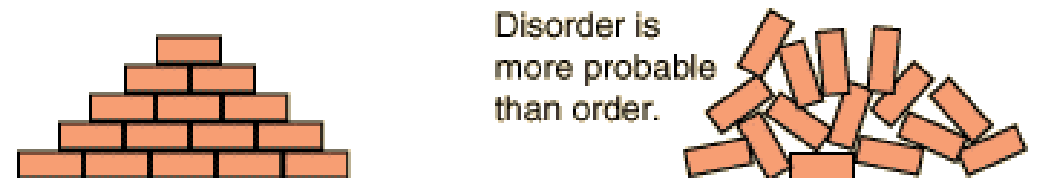

Entropy with only 2 outcomes

In binary case (2 outcomes)

$$H(p) = -p \log_2(p) - (1 - p) \log_2(1 - p)$$

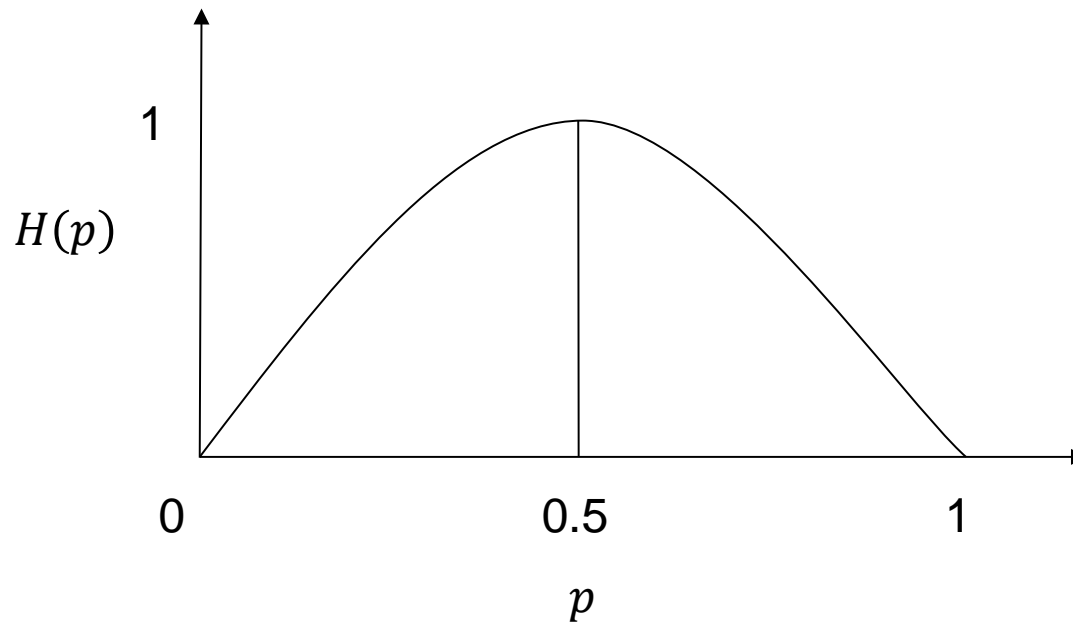

For multiple outcomes we have $\max H(p) = -\log_2\left(\frac{1}{n}\right) = \log_2(n)$

Information Gain

- $H(p)$ = entropy of class distribution at a particular node
- $H(p | A)$ = conditional entropy
 - Weighted average entropy of conditional class distribution
 - Partitioned the data according to the values in A
 - The sum of each partition given the group/class
- $\text{Gain}(A) = H(p) - H(p | A)$
- Simple rule in decision tree learning
 - At each internal node, split on the node with the largest information gain (or equivalently, with smallest $H(p|A)$)
- Note that by definition, conditional entropy can't be greater than the entropy

Entropy Example

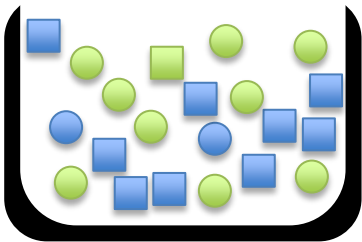

10 Squares
11 Circles

Class = color

grn = green; blu = blue; sq = square

- $H(p_{sq}) = -\frac{10}{21} \log_2 \frac{10}{21} - \frac{11}{21} \log_2 \frac{11}{21}$

- $H(p_{sq}) = 0.998$

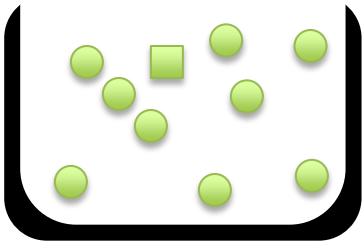

1 Square
9 Circles

- $H(p_{sq}|color) = p_{blu}H(p_{sq})_{blu} + p_{grn}H(p_{sq})_{grn}$

- $H(p_{sq})_{blu} = -\frac{9}{11} \log_2 \frac{9}{11} - \frac{2}{11} \log_2 \frac{2}{11}$

- $H(p_{sq})_{blu} = 0.684$

- $H(p_{sq})_{grn} = 0.469$

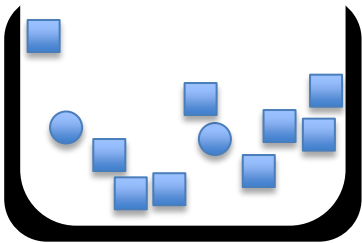

9 Square
2 Circles

- $Gain(color) = H(p_{sq}) + H(p_{sq}|color)$

Weighted average →

- $H(p_{sq}|color) = \frac{10}{21} * 0.469 + \frac{11}{21} * 0.684$

- $H(p_{sq}|color) = 0.582$

- $Gain(color) = 0.998 - 0.582$

- $Gain(color) = 0.416$

Root Node Example

For the training set, 6 positives, 6 negatives, $H(6/12, 6/12) = 1$ bit

positive (p) negative (1-p)



■

Consider the attributes *Patrons* and *Type*:

Conclude:

Patrons has the highest IG of all attributes and so is chosen by the learning algorithm as the root

Information gain is then repeatedly applied at internal nodes until all leaves contain only examples from one class or the other

Decision Tree Learned

Authors Created

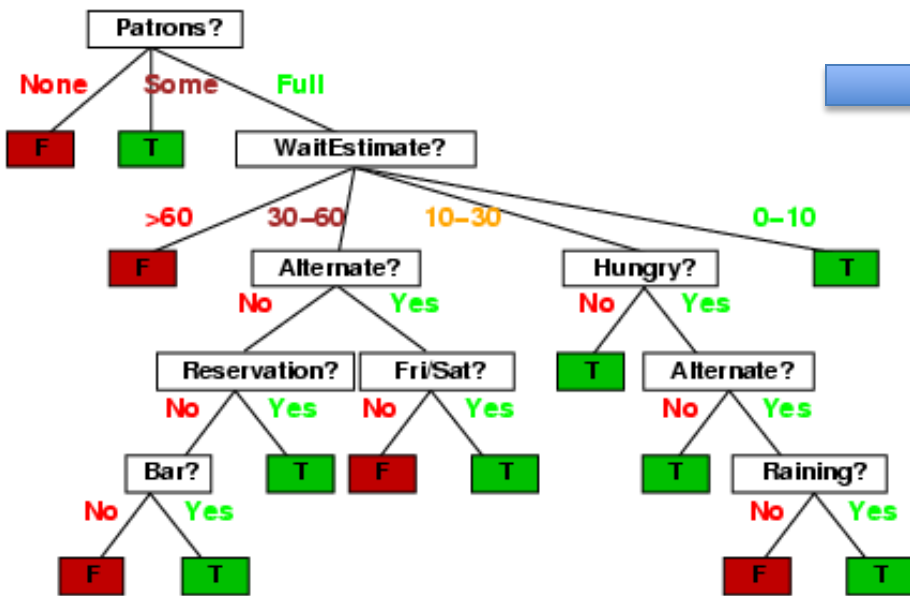

Learned

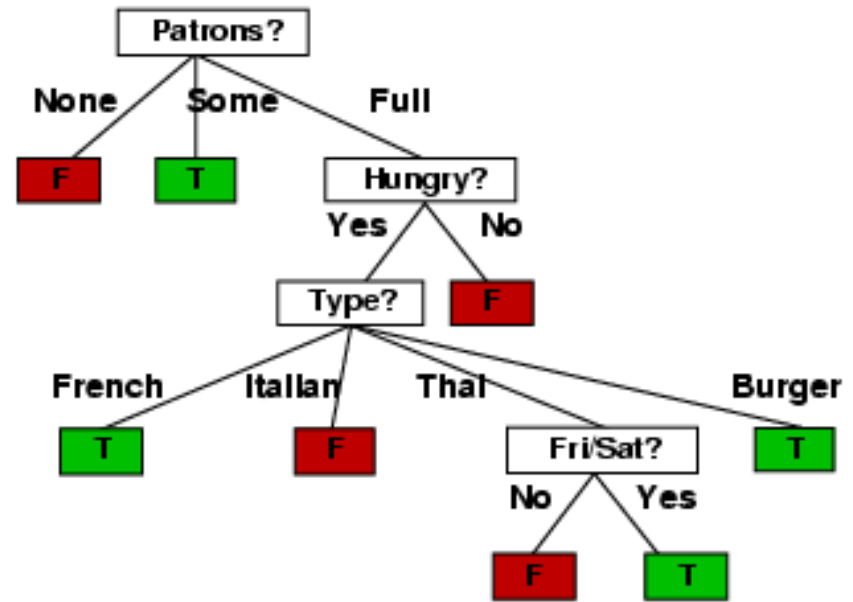

Assessing Performance

Training data performance is typically optimistic
e.g., error rate on training data

Reasons?

- classifier may not have enough data to fully learn the concept (but on training data we don't know this)
- for noisy data, the classifier may overfit the training data

In practice we want to assess performance "out of sample subsets"
how well will the classifier do on new unseen data? This is the
true test of what we have learned (like we take exams)

With large data sets we can partition our data into 2 subsets, train and test

- build a model on the training data
- assess performance on the test data

Training and Validation Data

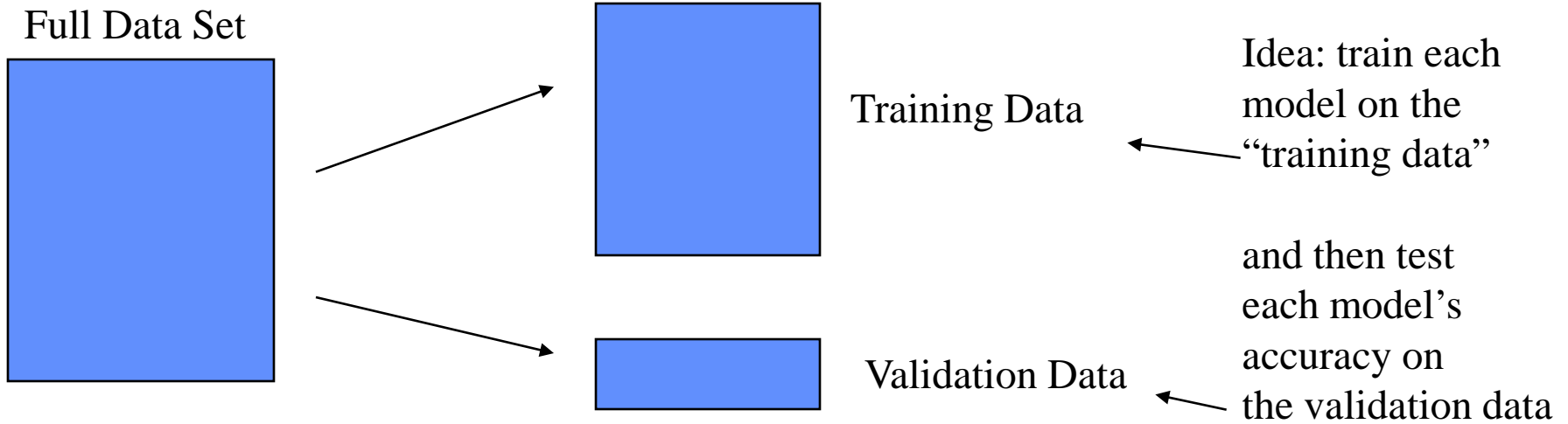

Overfitting and Underfitting

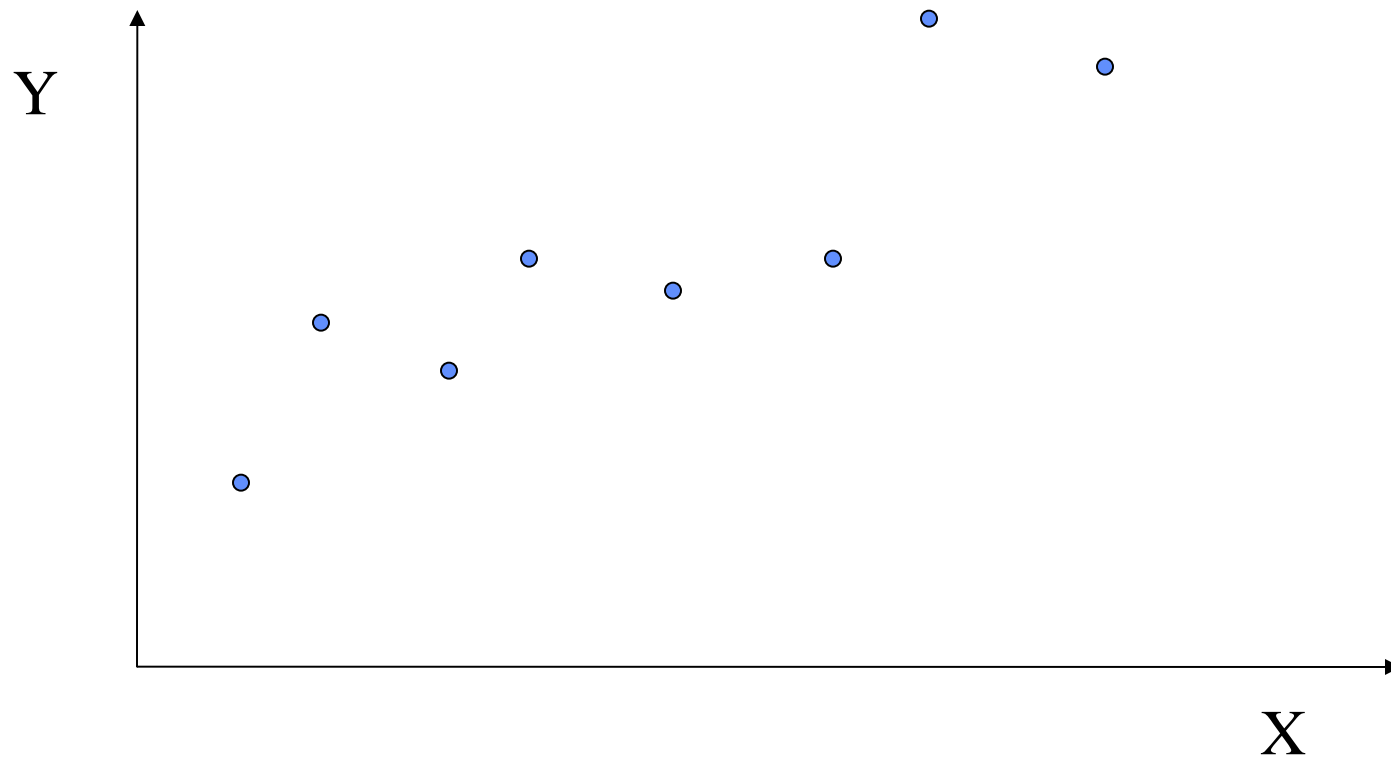

A Complex Model

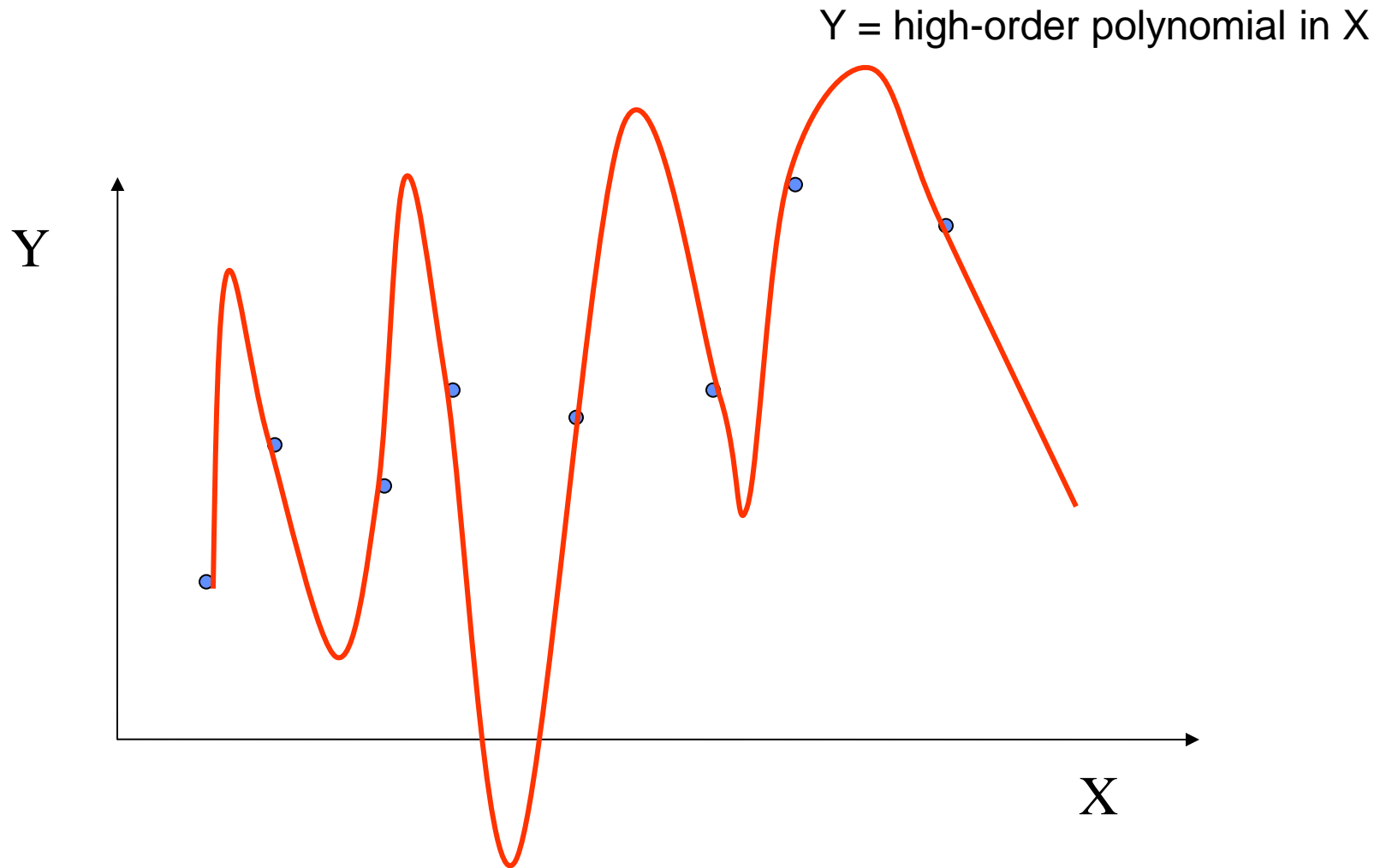

A Much Simpler Model

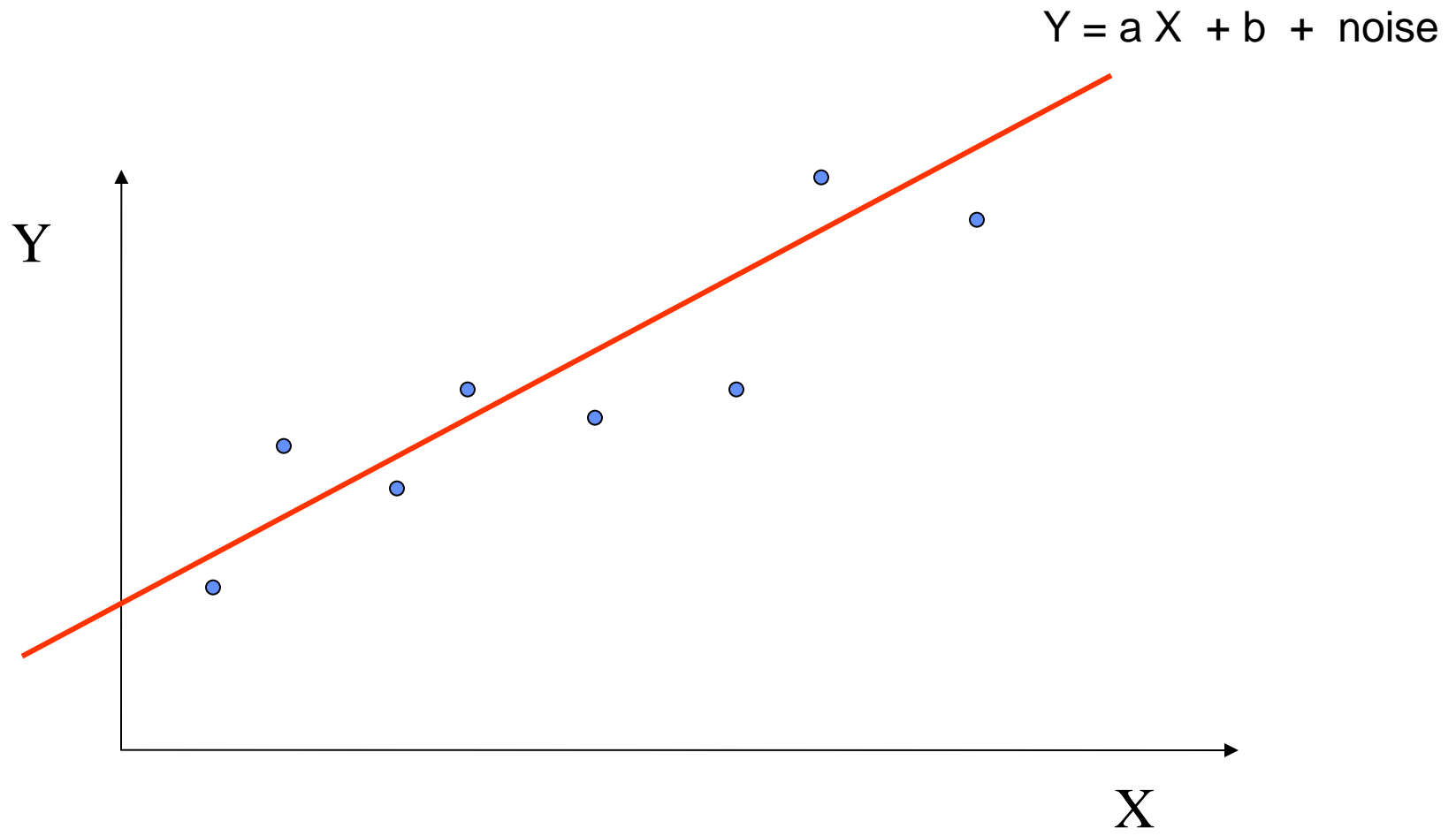

Example 2

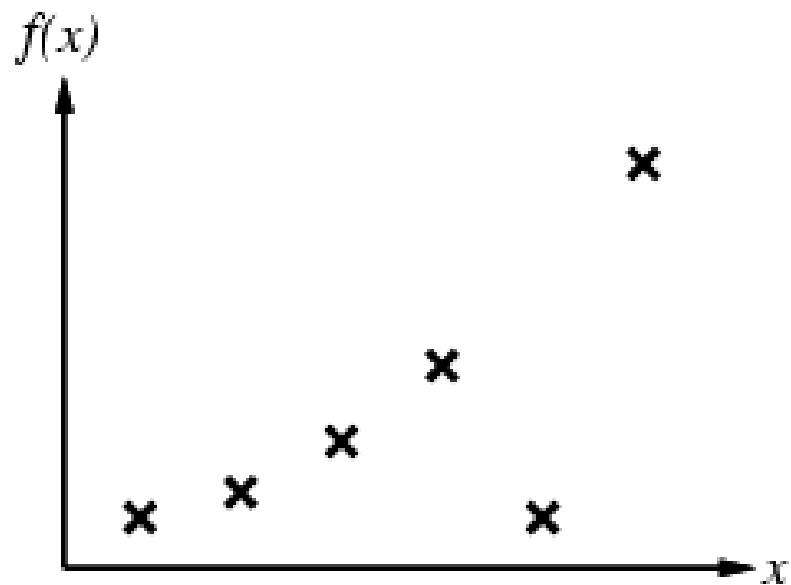

Example 2

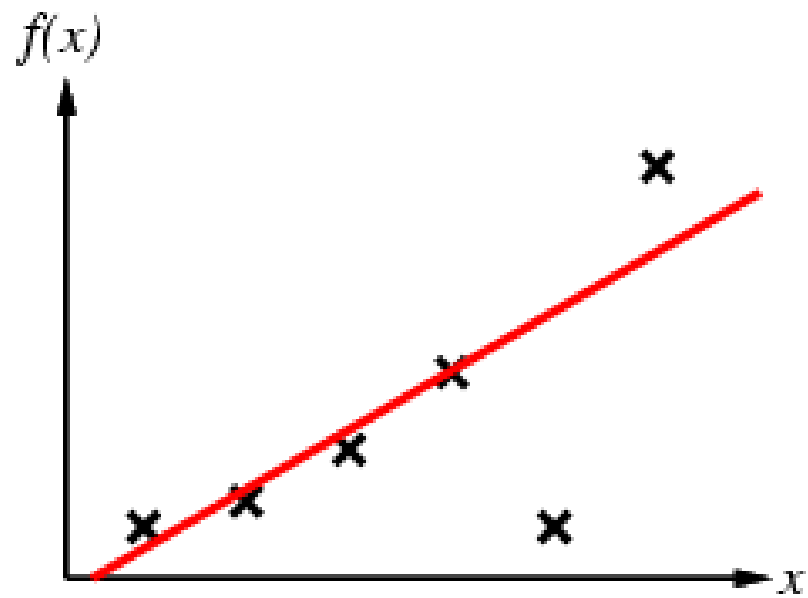

Example 2

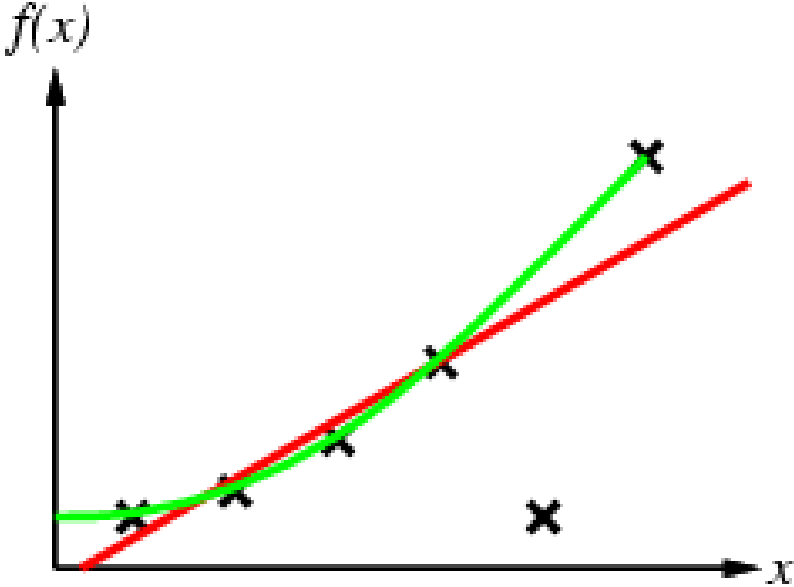

Example 2

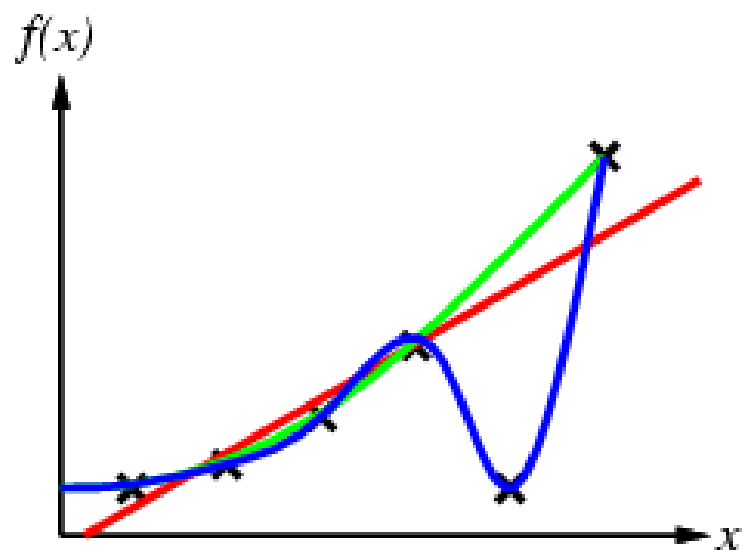

Example 2

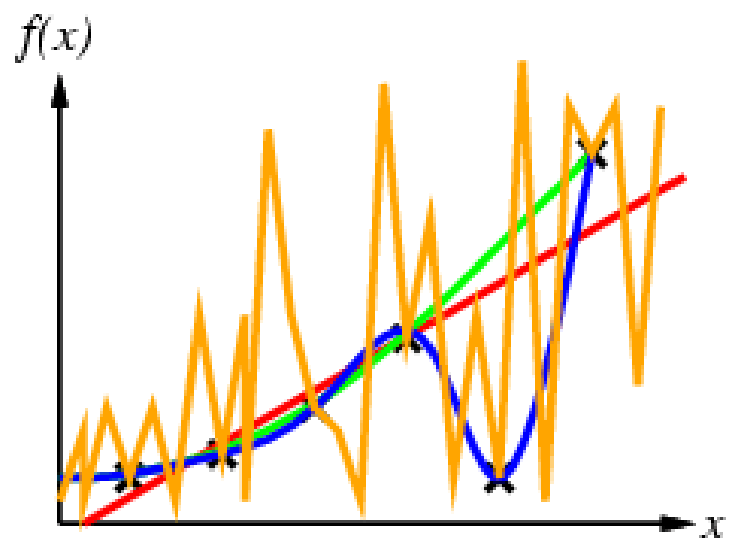

How Overfitting affects Prediction

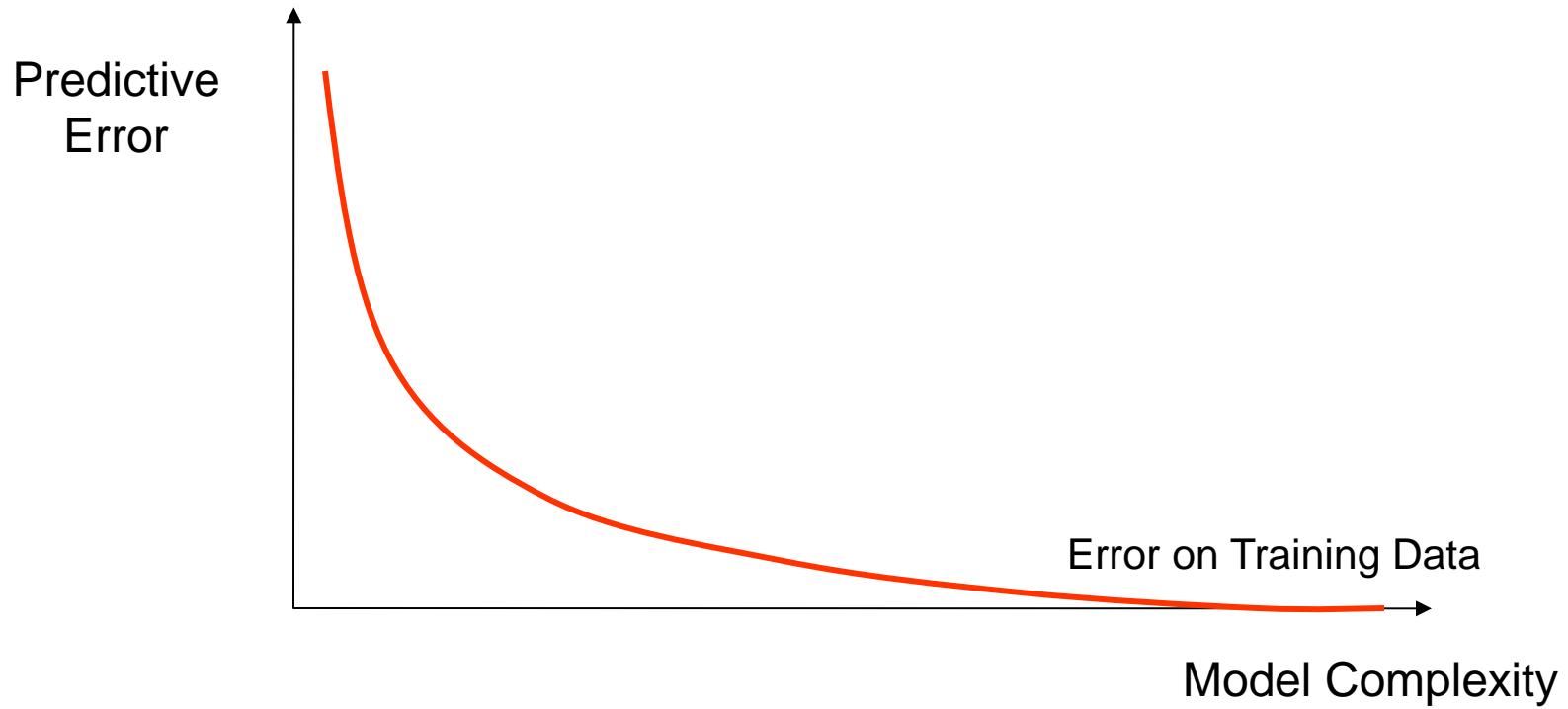

How Overfitting affects Prediction

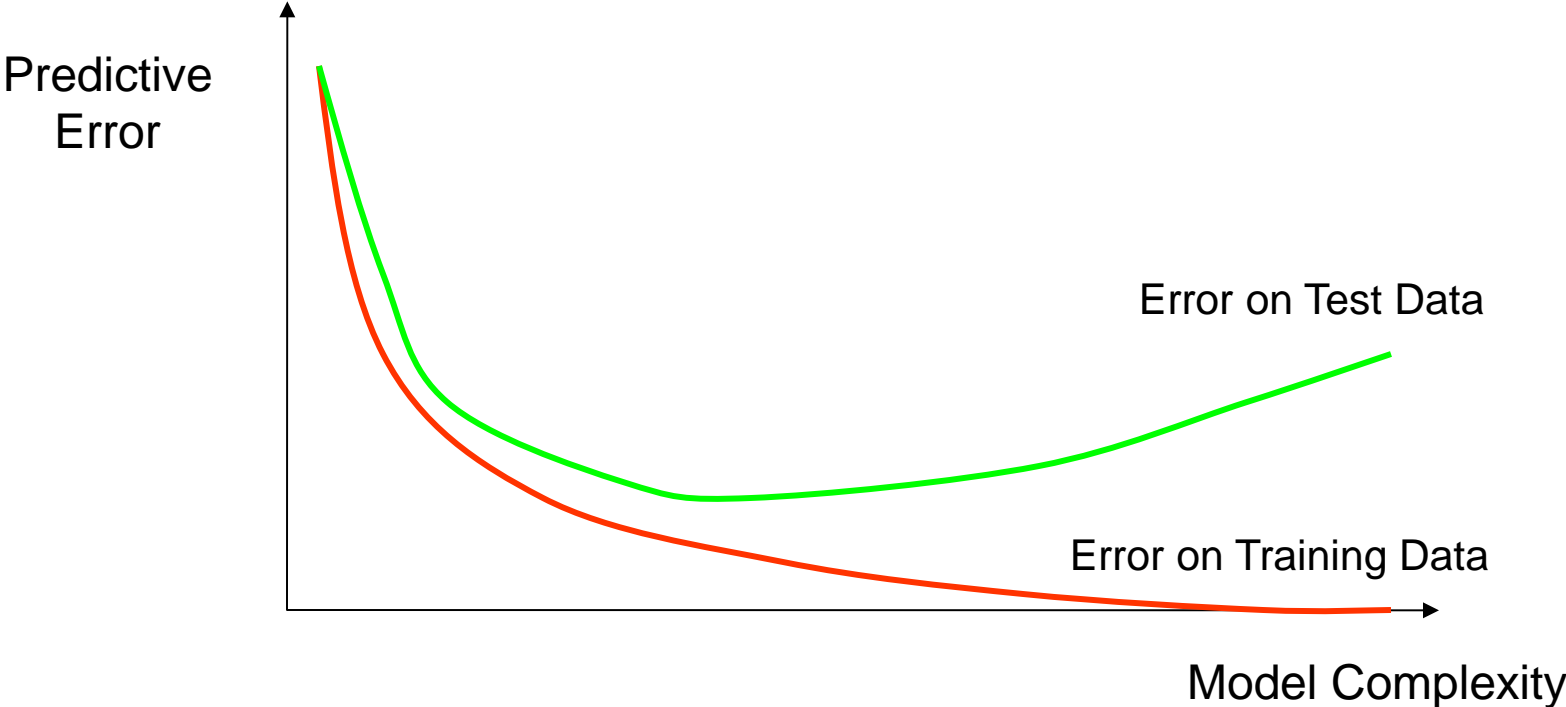

How Overfitting affects Prediction

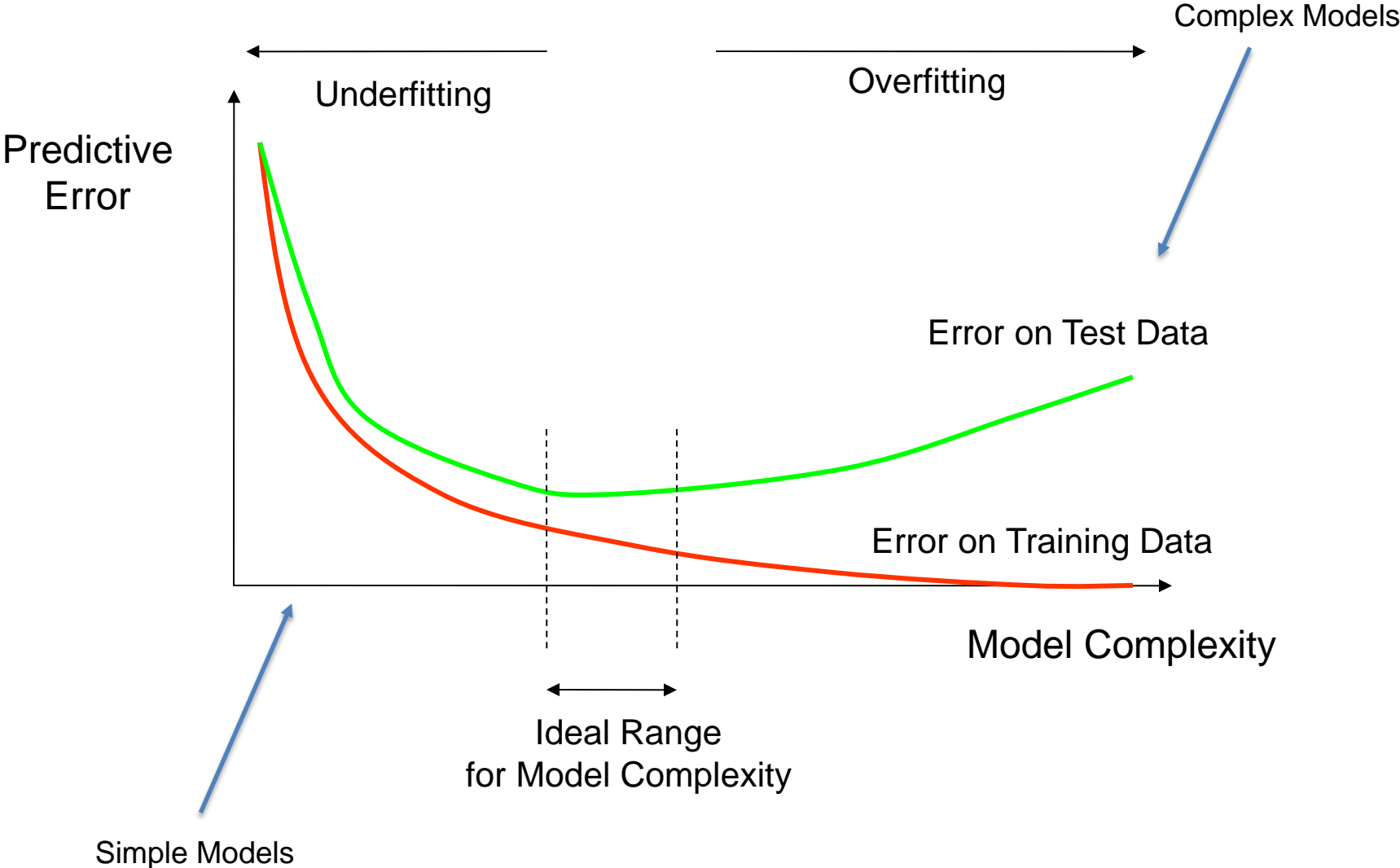

The k-fold Cross-Validation Method

- Why stop at a 90/10 “split” of the data?
 - In principle we could do this multiple times
- “k-fold Cross-Validation” (e.g., k=10)
 - randomly partition our full data set into k **disjoint subsets** (each roughly of size n/k , n = total number of training data points)
 - *for $i = 1:k$ (where $k = 10$)*
 - *train on 90% of the i_{th} data subset*
 - *Accuracy[i] = accuracy on 10% of the i_{th} data subset*
 - *end*
 - $\text{Cross-Validation-Accuracy} = 1/k \sum_i \text{Accuracy}[i]$
 - choose the method with the highest cross-validation accuracy
 - common values for k are 5 and 10
 - Can also do “leave-one-out” where $k = n$

Disjoint Validation Data Sets for $k = 5$

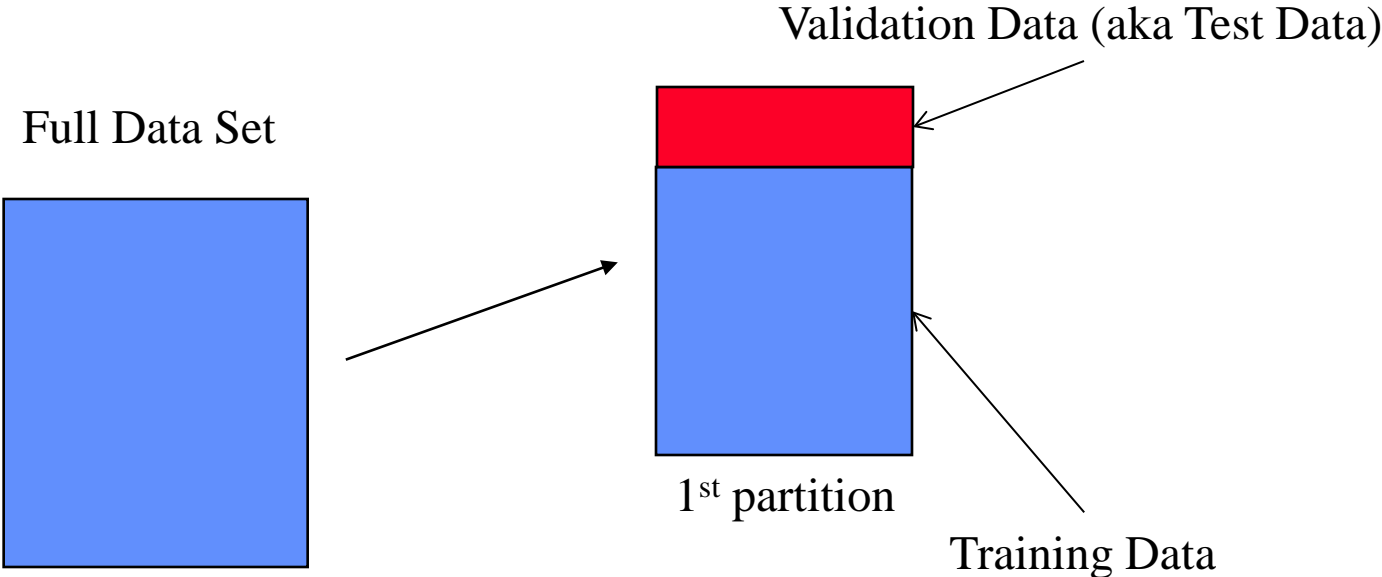

Disjoint Validation Data Sets for $k = 5$

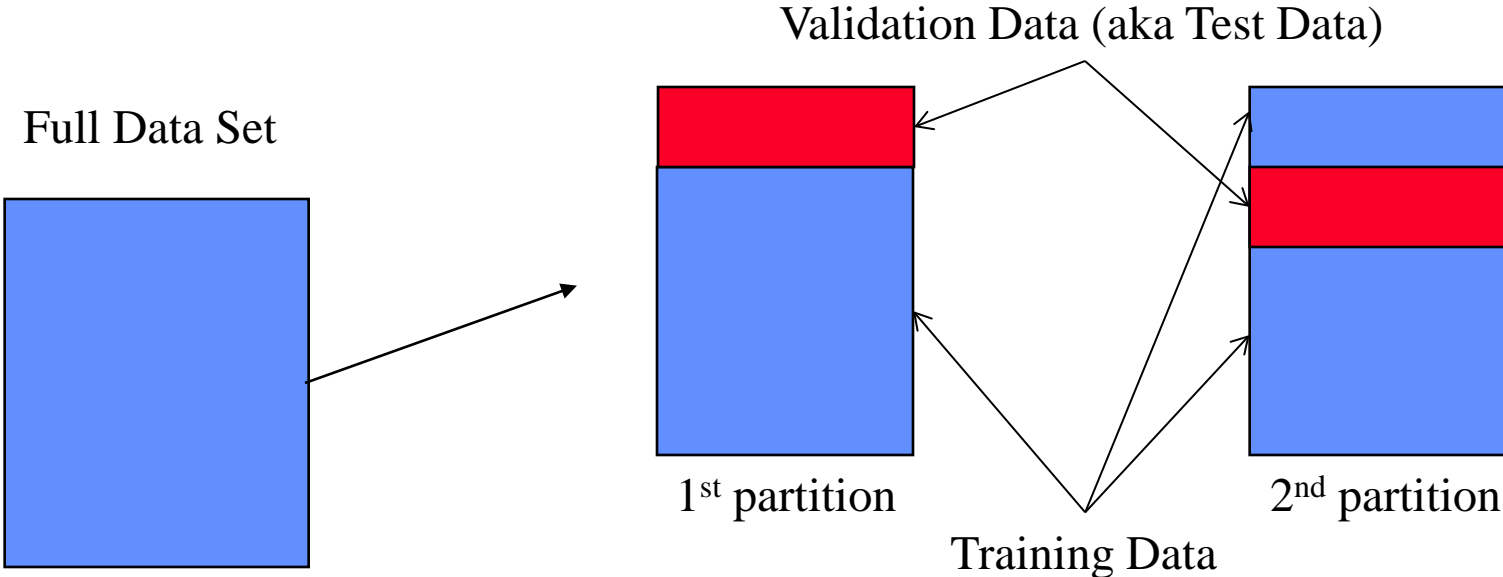

Disjoint Validation Data Sets for $k = 5$

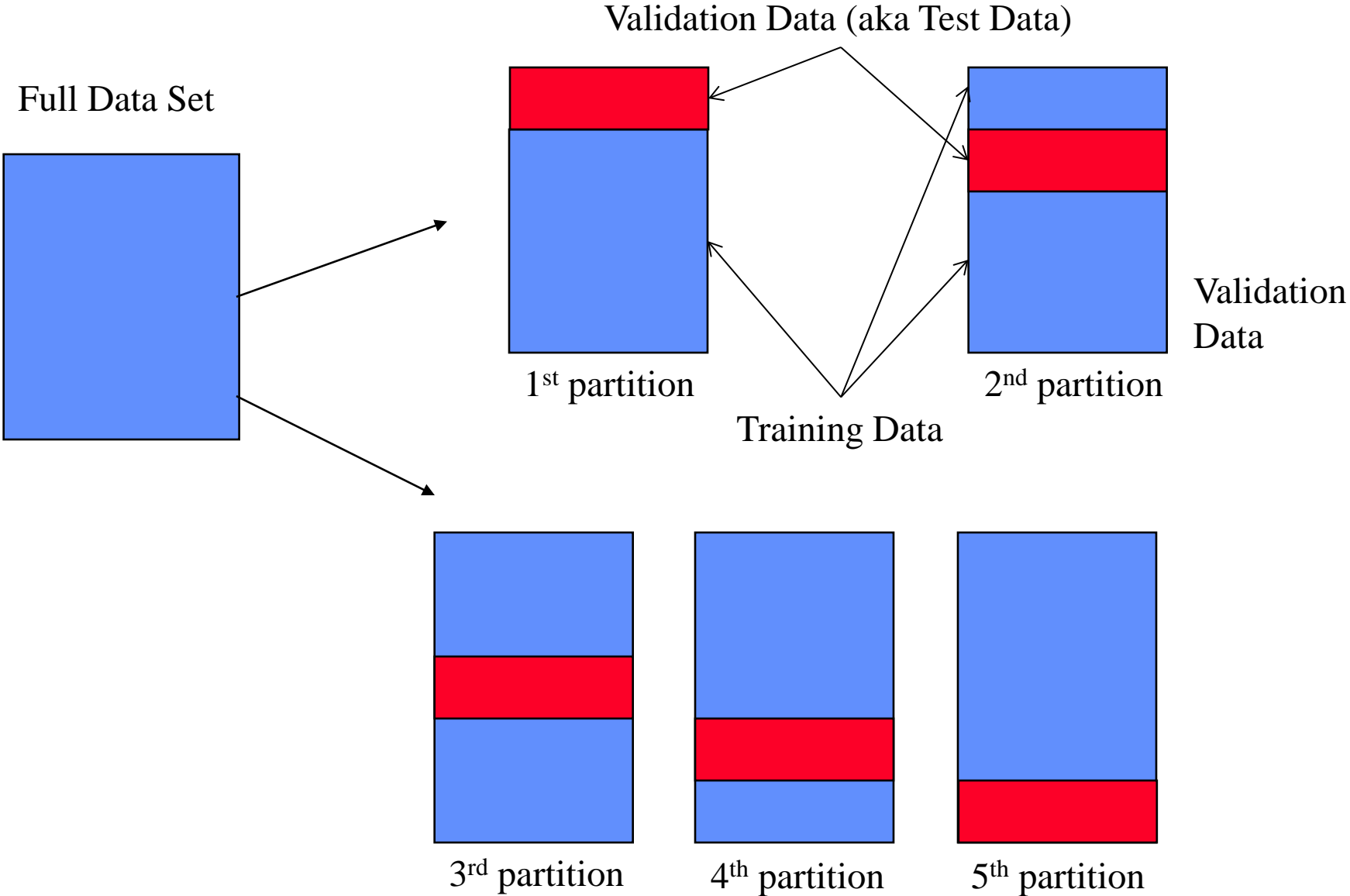

More on Cross-Validation

- Notes
 - cross-validation generates an approximate estimate of how well the learned model will do on “unseen” data
 - by averaging over different partitions it is more robust than just a single train/validate partition of the data
 - “k-fold” cross-validation is a generalization
 - partition data into disjoint validation subsets of size n/k
 - train, validate, and average over the v partitions
 - e.g., $k=10$ is commonly used
 - k-fold cross-validation is approximately k times computationally more expensive than just fitting a model to all of the data

You will be expected to know

- Understand Attributes, Error function, Classification, Regression, Hypothesis (Predictor function)
- What is Supervised and Unsupervised Learning?
- Decision Tree Algorithm
- Entropy
- Information Gain
- Tradeoff between train and test with model complexity
- Cross validation

Extra Slides

Summary

- Inductive learning
 - Error function, class of hypothesis/models $\{h\}$
 - Want to minimize E on our training data
 - Example: decision tree learning
- Generalization
 - Training data error is over-optimistic
 - We want to see performance on test data
 - Cross-validation is a useful practical approach
- Learning to recognize faces
 - Viola-Jones algorithm: state-of-the-art face detector, entirely learned from data, using boosting+decision-stumps

Importance of representation

Properties of a good representation:

- Reveals important features
- Hides irrelevant detail
- Exposes useful constraints
- Makes frequent operations easy-to-do
- Supports local inferences from local features
 - Called the “soda straw” principle or “locality” principle
 - Inference from features “through a soda straw”
- Rapidly or efficiently computable
 - It’s nice to be fast

Reveals important features / Hides irrelevant detail

- “You can’t learn what you can’t represent.” --- G. Sussman
- **In search:** *A man is traveling to market with a fox, a goose, and a bag of oats. He comes to a river. The only way across the river is a boat that can hold the man and exactly one of the fox, goose or bag of oats. The fox will eat the goose if left alone with it, and the goose will eat the oats if left alone with it.*
- **A good representation makes this problem easy:**

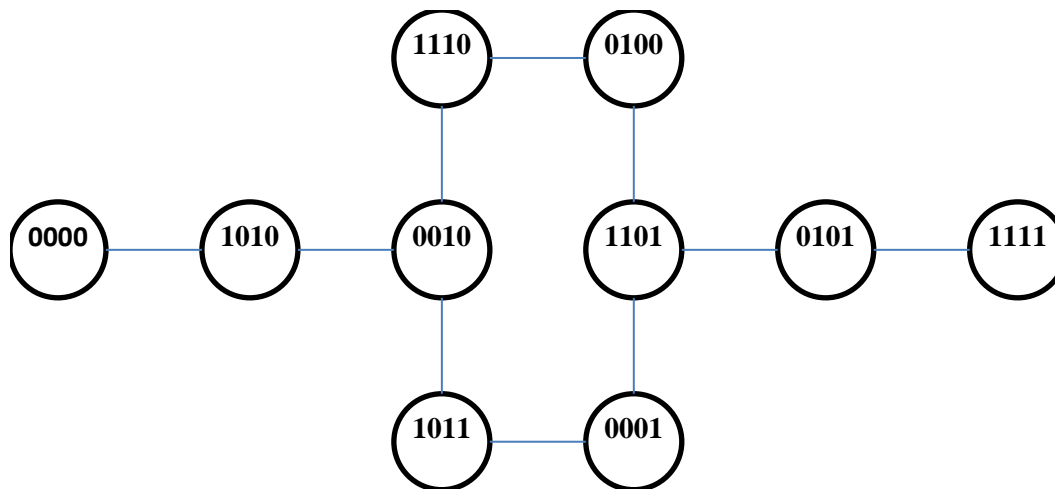

Entropy and Information

- Entropy $H(X) = E[\log 1/p(X)] = \sum_{x \in X} p(x) \log 1/p(x)$
 $= -\sum_{x \in X} p(x) \log p(x)$
 - Log base two, units of entropy are “bits”
 - If only two outcomes: $H = -p \log(p) - (1-p) \log(1-p)$
- Examples:

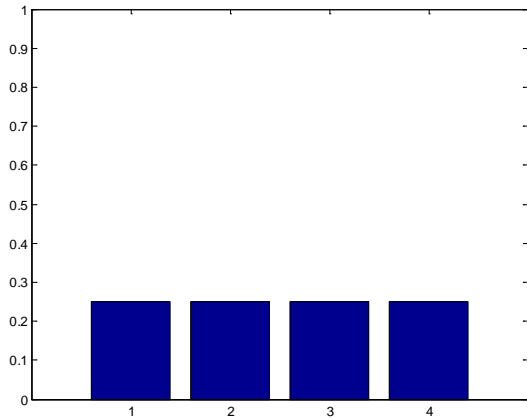

$$\begin{aligned} H(x) &= .25 \log 4 + .25 \log 4 + \\ &\quad .25 \log 4 + .25 \log 4 \\ &= \log 4 = 2 \text{ bits} \end{aligned}$$

Max entropy for 4 outcomes

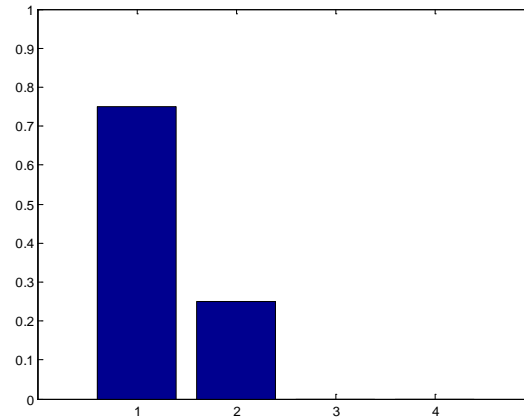

$$\begin{aligned} H(x) &= .75 \log 4/3 + .25 \log 4 \\ &= 0.8133 \text{ bits} \end{aligned}$$

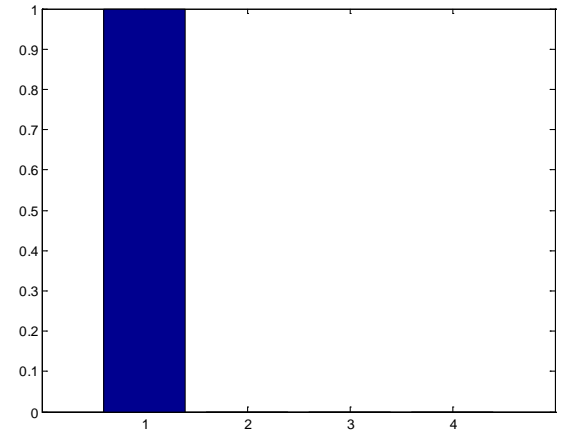

$$\begin{aligned} H(x) &= 1 \log 1 \\ &= 0 \text{ bits} \end{aligned}$$

Min entropy

Entropy and Information

- “Entropy” is a measure of randomness
 - How long a message does it take to communicate a result to you?
 - Depends on the probability of the outcomes; more predictable = shorter message
- Communicating fair coin tosses
 - Output: H H T H T T T H H H H T ...
 - Sequence takes n bits – each outcome totally unpredictable
- Communicating my daily lottery results
 - Output: 0 0 0 0 0 0 ...
 - Most likely to take one bit – I lost every day. **Lost: 0**
 - Small chance I’ll have to send more bits (won & when) **Won 1: 1(when)0**
Won 2: 1(when)1(when)0
- More predictable takes less length to communicate because it’s less random
 - Use a few bits for the most likely outcome, more for less likely ones

Example of Test Performance

Restaurant problem

- simulate 100 data sets of different sizes
- train on this data, and assess performance on an independent test set
- learning curve = plotting accuracy as a function of training set size
- typical “diminishing returns” effect (some nice theory to explain this)

